

PM427AS AC Motorized Roller 42.7 mm (1.68") Diameter

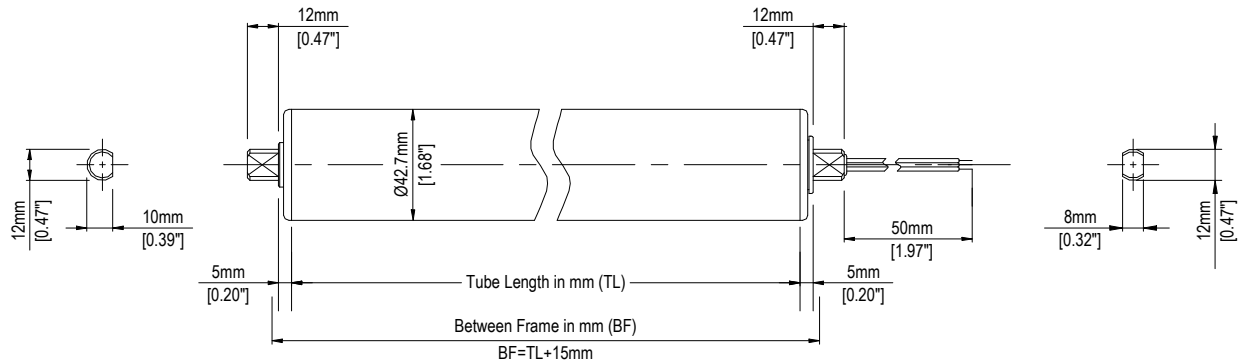

Standard model designation (example)

PM427AS-20-350-3-230

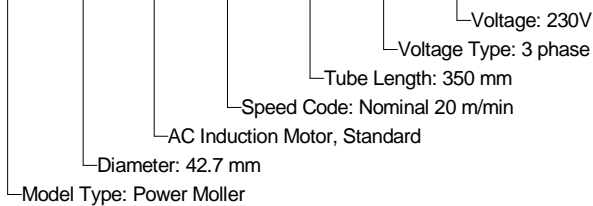

Standard Features

- Designed for slim and compact lines
- Thermally stable motor that can be operated 24/7 without fear of overheating
- 50 mm (1.97 in) motor cable
- Dustproof design (IP54)
- Straight, seamless tube
- Zinc plated, carbon steel tube
- Class E insulation

Environment

- Ambient Temperature -10~40°C (14~104°F)
- <90% Relative Humidity (No condensation)
- No corrosive gases
- Vibration <0.5G

Operation

- Cycle: 3s ON; 2s OFF
- Continuous or intermittent duty
- Do not exceed 150% of no-load speed

Mounting Hardware

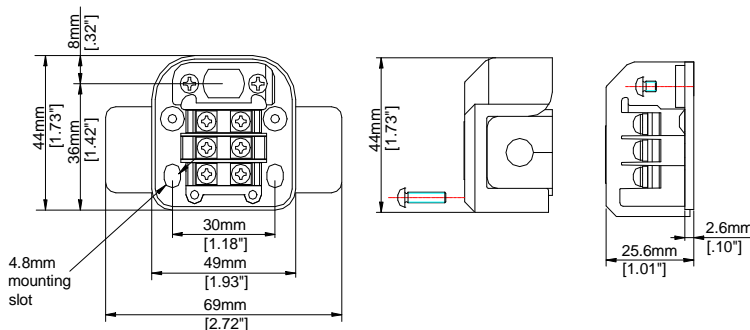

Standard

- Supplied with E-920 terminal block to secure shaft on cable side

E-920 Terminal Block

ITOHDENKI USA, INC.

135 Stewart Road Hanover Industrial Estates
Hanover Township, PA 18706
P: 570-820-8811 F: 570-820-8838
E: info@itohdenki.com www.itohdenki.com
Specifications subject to change without notice.

PM427AS AC Motorized Roller 42.7 mm (1.68") Diameter



PM427AS Performance Specifications

3Φ 230V 60Hz						
Speed Code	Speed No-Load (ft/min)	Tangential Force Starting (lb)	Torque Starting (in-lb)	Current		
				No-Load (A)	Rated (A)	Starting (A)
5	18.4	11.9	10.0	0.05	0.05	0.07
8	27.9	7.9	6.6	0.05	0.05	0.07
10	42.3	5.2	4.3	0.05	0.05	0.07
15	59.1	4.3	3.6	0.05	0.05	0.07
20	90.2	2.8	2.4	0.05	0.05	0.07
30	140.4	1.8	1.5	0.05	0.05	0.07

1Φ 115V 60Hz						
Speed Code	Speed No-Load (ft/min)	Tangential Force Starting (lb)	Torque Starting (in-lb)	Current		
				No-Load (A)	Rated (A)	Starting (A)
5	18.4	6.0	5.0	0.11	0.11	0.13
8	27.9	4.0	3.4	0.11	0.11	0.13
10	42.3	2.6	2.2	0.11	0.11	0.13
15	59.1	2.3	1.9	0.11	0.11	0.13
20	90.2	1.6	1.3	0.11	0.11	0.13
30	140.4	0.9	0.8	0.11	0.11	0.13

▪ **Available Options:**

- Brake
- Drip-proof IP-55
- Waterproof IP-65
- Wide Range of rubber laggings
- V-belt pulley
- Idler rollers

Minimum Tube Length

Option	Without Spring Loaded Shaft	With Spring Loaded Shaft
None	200 mm (7.87")	220 mm (8.66")
Brake	250 mm (9.84")	270 mm (10.63")
Drip-proof	200 mm (7.87")	220 mm (8.66")
Waterproof	250 mm (9.84")	250 mm (9.84")

ITOHDENKI USA, INC.
 135 Stewart Road Hanover Industrial Estates
 Hanover Township, PA 18706
 P: 570-820-8811 F: 570-820-8838
 E: info@itohdenki.com www.itohdenki.com
 Specifications subject to change without notice.