

PM570AS AC Motorized Roller 57.0 mm (2.24") Diameter

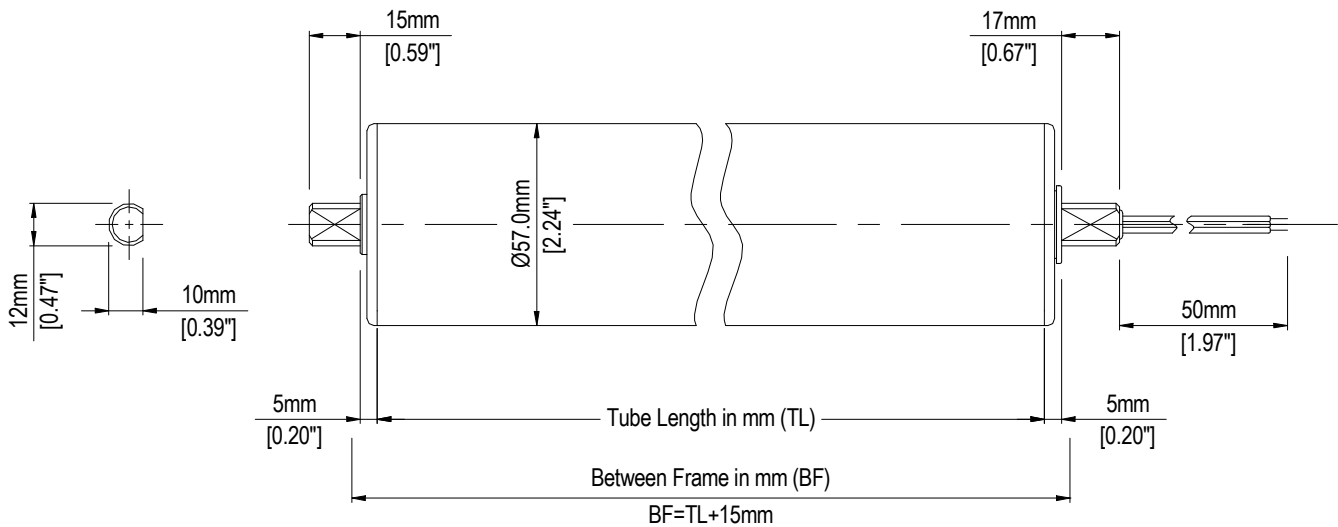

Standard model designation (example)

PM570AS-40-650-3-230

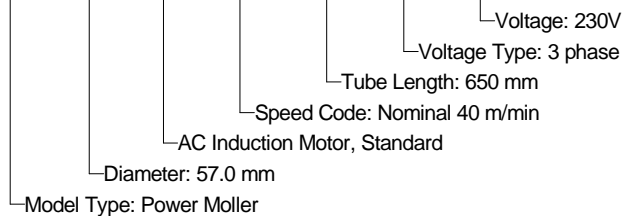

Standard Features

- Designed for medium to heavy load handling conveyors
- Thermally stable motor that can be operated 24/7 without fear of overheating
- 12 mm (0.47") dia. D-shafts
- Spring-loaded shaft (non-cable side)
- 50 mm (1.96") motor leads
- Dustproof design (IP54)
- Straight, seamless tube
- Zinc plated, carbon steel tube
- Class E insulation

Environment

- Ambient Temperature 0~40°C (32~104°F)
- <90% Relative Humidity (No condensation)
- No corrosive gases
- Vibration <0.5G

Operation

- Cycle: 3s ON; 2s OFF
- Continuous or intermittent duty
- Do not exceed 150% of no-load speed

ITOHDENKI USA, INC.

135 Stewart Road Hanover Industrial Estates
Hanover Township, PA 18706
P: 570-820-8811 F: 570-820-8838
E: info@itohdenki.com www.itohdenki.com
Specifications subject to change without notice.

PM570AS AC Motorized Roller 57.0 mm (2.24") Diameter



Popular Options*

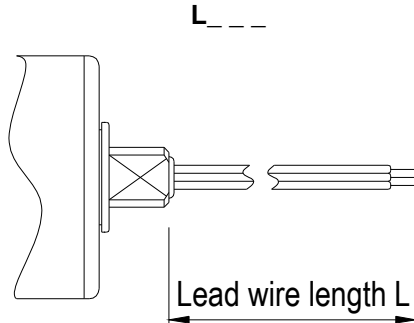

L050 - 500mm lead wire
[In increments of 500mm]

P2 (double grooved tube)

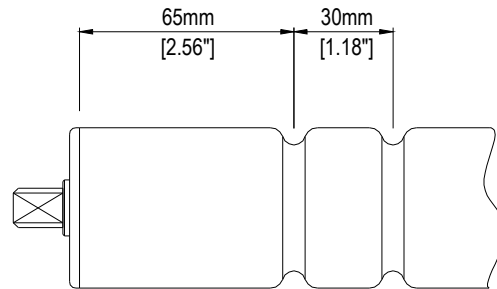

[Other groove locations also available]

KF option

- Mounting hardware not included
(ordering purposes only)

*Ask an Itoh Denki representative for other available options

Mounting Hardware

A-200

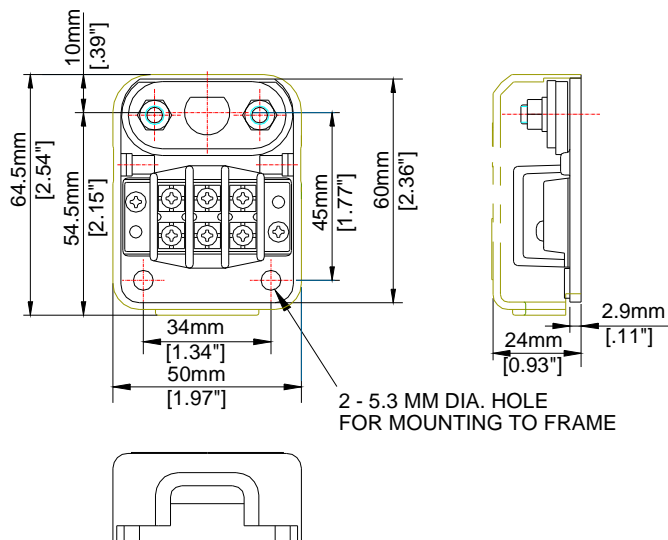

Standard

- Supplied with A-200 to secure shaft on cable side

ITOHDENKI USA, INC.

135 Stewart Road Hanover Industrial Estates
Hanover Township, PA 18706
P: 570-820-8811 F: 570-820-8838
E: info@itohdenki.com www.itohdenki.com
Specifications subject to change without notice.

PM570AS AC Motorized Roller 57.0 mm (2.24") Diameter



PM570AS Performance Specifications

3Φ 230V 60Hz						
Speed Code	Speed No-Load (ft/min)	Tangential Force Starting (lb)	Torque Starting (in-lb)	Current		
				No-Load (A)	Rated (A)	Starting (A)
4	14.8	27.9	31.2	0.06	0.06	0.13
5	20.3	20.4	22.8	0.06	0.06	0.13
8	29.8	14.0	15.7	0.06	0.06	0.13
9	37.4	11.1	12.5	0.06	0.06	0.13
10	41.0	10.2	11.4	0.06	0.06	0.13
13	51.5	8.1	9.0	0.06	0.06	0.13
15	62.6	7.7	8.6	0.06	0.06	0.13
20	89.5	5.4	6.0	0.06	0.06	0.13
30	130.5	3.7	4.2	0.06	0.06	0.13
45	170.9	2.8	3.2	0.06	0.06	0.13
50	187.9	2.5	2.8	0.06	0.06	0.13
60	247.3	2.0	2.2	0.06	0.06	0.13

1Φ 115V 60Hz						
Speed Code	Speed No-Load (ft/min)	Tangential Force Starting (lb)	Torque Starting (in-lb)	Current		
				No-Load (A)	Rated (A)	Starting (A)
4	14.8	11.5	12.8	0.17	0.19	0.28
5	20.3	8.4	9.4	0.17	0.19	0.28
8	29.8	5.8	6.5	0.17	0.19	0.28
9	37.4	4.6	5.1	0.17	0.19	0.28
10	41.0	4.2	4.7	0.17	0.19	0.28
13	51.5	3.8	4.2	0.17	0.19	0.28
15	62.6	3.3	3.7	0.17	0.19	0.28
20	89.5	2.4	2.7	0.17	0.19	0.28
30	130.5	1.7	1.9	0.17	0.19	0.28
45	170.9	1.3	1.4	0.17	0.19	0.28
50	187.9	1.1	1.2	0.17	0.19	0.28
60	247.3	0.9	1.0	0.17	0.19	0.28

ITOHDENKI USA, INC.
 135 Stewart Road Hanover Industrial Estates
 Hanover Township, PA 18706
 P: 570-820-8811 F: 570-820-8838
 E: info@itohdenki.com www.itohdenki.com
 Specifications subject to change without notice.

PM570AS AC Motorized Roller 57.0 mm (2.24") Diameter



▪ **Available Options:**

- Brake
- Dripproof IP-55
- Waterproof IP-65
- Electric Clutch
- Wide Range of rubber laggings
- V-belt pulley
- Idler rollers

Minimum Tube Length

Option	Without Spring Loaded Shaft	With Spring Loaded Shaft
None	200 mm (7.87")	250 mm (9.84")
Brake	250 mm (9.84")	300 mm (11.81")
Dripproof	200 mm (7.87")	260 mm (10.24")
Waterproof	260 mm (10.24")	290 mm (11.42")

ITOHDENKI USA, INC.

135 Stewart Road Hanover Industrial Estates
Hanover Township, PA 18706
P: 570-820-8811 F: 570-820-8838
E: info@itohdenki.com www.itohdenki.com
Specifications subject to change without notice.