

# CBK-109FN/FP

Driver Card Manual



## FEATURES:

- Designed for use with the high torque FH & KT series rollers.
- Adjustable acceleration and deceleration time (0 to 2.5s)
- Stable speed operation
- Switch for manual or automatic recovery of the thermal overload device
- One (1) DIP switch combined with one (1) rotary switch to select up to 20 different fixed speeds
- DIP switch to select the condition of error signal activity; during normal status or abnormal status
- Forcibly stops the motor if motor lock or thermal overload error lasts for 0.5 seconds or more.
- Three (3) LEDs (green, red, & orange) to identify the type of error and number of error occurrences
- Pulse signal output to indicate motor revolution
- RoHS and EMC Conformity
- Negative Load Control to keep set speed. Control the speed when the speed exceeds the set speed by 10% or more. Control the speed when the speed exceeds the set speed by 12% or more while accelerating or decelerating.

Specifications subject to change without notice

Revised 7/1/2024

<b>SUBJECT</b>	<b>PAGE</b>
<b>Features</b>	1
<b>Specifications</b> -Dimensions -Connections & Wiring	3-5
<b>Operation</b> -DIP Switches -Potentiometer -Internal Switches -Alternate Model Designations -Settings for Turning Direction	6-7
<b>LED and Error Indications</b> -Red Error Indication -Orange Error Indication -Motor Pulse Output Signal	8-9
<b>Speed Change Tables</b> -PM486FH -PM570KT -PM605KT -PM635KT	10-13
<b>Installation Precautions</b>	14
<b>Revision History</b>	15

## DIMENSIONS:

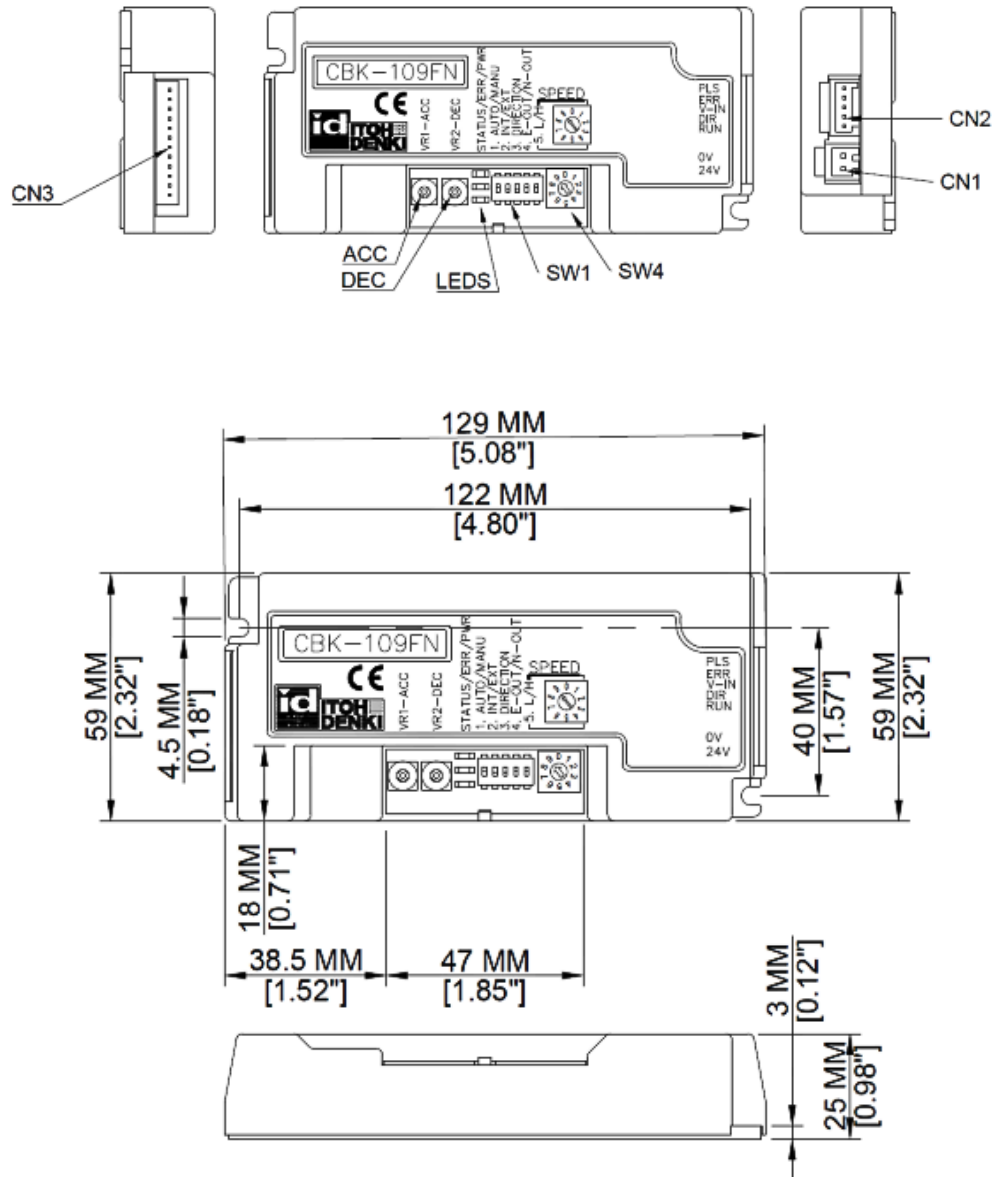

## CONNECTIONS & WIRING:

	12 PIN connector for Motor	Male Connector on Card JST #S12B-XH-A	Female Connector for Wiring JST #XHP-12
PIN	Description		
1	GND – Grey		<p>Wire size: 28~22AWG &amp; 24~22AWG motor phases</p> <p>Terminal Pins: JST #SXH-001T-P0.6</p>
2	+12V DC – Blue		
3	Motor phase U – Red		
4	Motor phase U – Pink		
5	Motor phase V – White		
6	Motor phase V – Yellow		
7	Motor phase W – Black		
8	Motor phase W – Brown		
9	Hall sensor U - Violet		
10	Hall sensor V – Orange		
11	Hall sensor W – Green		
12	Thermistor – Light Blue		

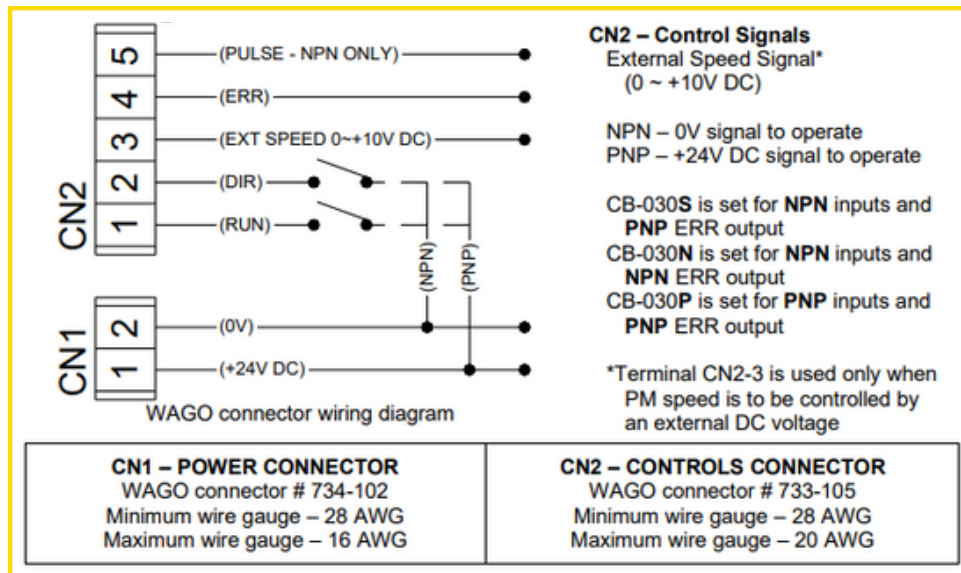

Press down spring clamp in connector with a small screwdriver.  
Insert leads in proper order.  
Lead should be stripped approx: 0.31~0.35”  
WAGO connector (included) must be inserted and/or pulled out carefully, so as not to damage other parts

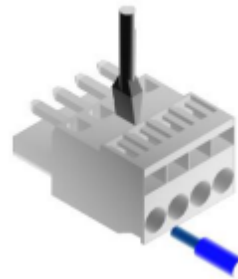

- ELECTRICAL:** 24V DC  $\pm 10\%$  input
- Battery
  - Power Supply: full wave rectified with smoothed current and  $<10\%$  Ripple
- Power ON delay  $<1s$   
6.6~7.4A locking current Input signal level for activation
- 0V (3V or less) for NPN
  - 24V (18V or greater) for PNP
- Output (Error and Motor Pulse) signals
- Open collector 24V, 25mA or less
  - NPN
  - PNP (selectable for Error only)

**APPLICABLE MODELS:** FH, KT

**BRAKE:** Dynamic (Electric)

- PROTECTION:** Thermal protection reaction
- 85°C (185°F) on the PCB
  - 105°C (221°F) in the motor
- Built-in 10A fuse for power supply protection  
Built-in diode for incorrect wiring protection  
Back EMF
- motor voltage over 40V  $\rightarrow$  2 sec / 60V  $\rightarrow$  0.1 sec

**ENVIRONMENT:** Temperature 0~40°C (32~104°F)  
<90% Relative Humidity (No condensation)  
No corrosive gas  
Vibration  $<0.5G$

**TERMINAL:** 2-Pole WAGO (CN1)                      5-Pole WAGO (CN2)

- (M) 734-162                                      • (M) 733-365
- (F) 734-102                                      • (F) 733-105

**MOTOR CONNECTOR:** 12-Pole JST

- (M) S12B-XH-A
- (F) XHP-12 (socket terminal SXH001P-P0.6)

## DIP SWITCHES – USER SETTINGS:

DIP-SW	Function	ON Setting	OFF Setting	Initial Setting
1	Thermal Device Recovery	Manual	Automatic (Restarts 1 min after cool down)	ON
2	Speed Change Selection	External (0~10V DC applied)	Internal (DIP & Rotary switches)	OFF
		See Speed Change Tables		
3	DIR (no external DIR signal; viewed from cable side)	FH – CCW KT – CW	FH – CW KT – CCW	OFF
4	Error Signal Activity	Active during normal status	Active during abnormal status	ON
5	Internal Speed Change	High Speed	Low Speed	ON
Rotary	Internal Speed Change			9

## POTENTIOMETERS:\*

- VR1 – Acceleration Adjust acceleration time from 0~2.5 s after the RUN signal is applied
- VR2 – Deceleration Adjust deceleration time from 0~2.5 s after the RUN signal is removed
- \* VRs turn 270°

## INTERNAL SWITCHES:\*











Switch	Function	Position for Signal Type		Initial Setting
		NPN Setting	PNP Setting	
SW2	Inputs (RUN/DIR)	LEFT	RIGHT	LEFT
SW3	Output (ERR)	LEFT	RIGHT	LEFT

## ALTERNATE MODEL DESIGNATION:

\* The following input/output settings are available from the factory, if necessary:

CBK-109FN – NPN input and output signals  
 CBK-109FP – PNP input and output signals

## SETTING FOR TURNING DIRECTION:

	SW 1-3	
	ON 	OFF 
KT type	CW 	CCW 
	CCW 	CW 
FH type	CCW 	CW 
	CW 	CCW 

\*Turning direction viewed from the MDR's power cable side

# LED AND ERROR INDICATIONS:

LED 1: Green (power)

LED 2: Red (error condition)

LED 3: Orange (error occurrence)

LED	Green	Red	ERR Output (DIP-SW4 setting)		Effect	Solution*
			OFF	ON		
Normal Operation	● (ON)	● (OFF)	● (OFF)	● (ON)	-	-
No Power	● (OFF)	● (OFF)	● (OFF)	● (OFF)	-	Supply power (24V DC)
Fuse Blown	● (OFF)	●●●● ●●●● Blinks (6Hz)	● (ON)	● (OFF)	Circuit board damage	Card must be replaced
Current Limit (while running)	● (ON)	●●●● ●●●● Blinks (6Hz)	● (OFF)	● (ON)	-	Normal during start-up; May indicate overload during operation
Low Voltage (<15V)	● (ON)	●●●● ●●●● Blinks (6Hz)	● (ON)	● (OFF)	≤ 15V DC	Motor does not operate
Thermal Protection**	● (ON)	● (ON)	● (ON)	● (OFF)	Motor or PCB overheated	Motor stops 4s after reaction
Motor Lock	● (ON)	●● Blinks (1Hz)	● (ON)	● (OFF)	Motor does not turn for 0.5s	Motor stops
Motor Not Plugged In	● (ON)	● (ON)	● (ON)	● (OFF)	-	Motor does not operate
Back EMF Error	● (OFF)	●●●● ●●●● Blinks (6Hz)				







\*To reset an error condition: Remove input signals; then reapply an input signal to either CN2-1 or CN2-2

\*\*If thermal device recover is set for automatic, the error will reset 1 min after the temperature has reached operating range.

# LED AND ERROR INDICATIONS:





## RED LED INDICATION: - ERROR CONDITION:

The **red** LED indicates the current error condition in conjunction with the green LED

No Error	Motor Lock	Low Voltage (<15V)	Fuse Blown*	Current Limit*	Thermal Protection	Back EMF
 (OFF)	 Blinks (1Hz)	 Blinks (6Hz)	 Blinks (6Hz)	 Blinks (6Hz)	 (ON)	 Blinks (6Hz)

## ORANGE LED INDICATION: - ERROR OCCURRENCE:

The **orange** LED indicates the number of consecutive occurrences of the current error condition indicated by the red LED. If the previous error differs from the current error, a combination status will be displayed.

No Error	1	2	≥3	Combination
 (OFF)	 (OFF)	 Blinks (1Hz)	 (ON)	 Blinks (6Hz)

\* The occurrences of “fuse blown” and “current limit” errors are not recorded.

## MOTOR PULSE OUTPUT SIGNAL

- NPN (OV) output from CN2-5
- Two (2) pulses per motor revolution

# SPEED CHANGE TABLES

## PM486FH

Internal Speed Variation		Analog Voltage	MDR Nominal Speed (FPM)	
SW 1-5	SW 5	Input	255	55
ON	9	9.6~9.9	799.34	175.48
	8	9.1~9.4	799.34	175.48
	7	8.6~8.9	799.34	175.48
	6	8.1~8.4	799.34	175.48
	5	7.6~7.9	771.13	169.248
	4	7.1~7.4	730.78	160.392
	3	6.6~6.9	648.46	142.352
	2	6.1~6.4	608.11	133.496
	1	5.6~5.9	567.77	124.64
	0	5.1~5.4	527.2	115.784
OFF	9	4.6~4.9	487.08	106.928
	8	4.1~4.4	446.74	98.072
	7	3.6~3.9	405.08	88.888
	6	3.1~3.4	364.74	80.032
	5	2.6~2.9	324.39	71.176
	4	2.1~2.4	284.05	62.32
	3	1.6~1.9	243.70	53.464
	2	1.1~1.4	203.36	44.608
	1	0.6~0.9	163.02	35.752
	0	0.1~0.4	121.03	26.568

# SPEED CHANGE TABLES

## PM570KT

Internal Speed Variation		Analog Voltage	MDR Nominal Speed (FPM)	
SW 1-5	SW 5	Input	28	15
ON	9	9.6~9.9	196.14	51.496
	8	9.1~9.4	184.99	48.872
	7	8.6~8.9	176.79	46.576
	6	8.1~8.4	168.26	44.28
	5	7.6~7.9	159.74	41.984
	4	7.1~7.4	151.54	39.688
	3	6.6~6.9	134.81	35.424
	2	6.1~6.4	125.95	33.128
	1	5.6~5.9	117.75	30.832
	0	5.1~5.4	109.55	28.864
OFF	9	4.6~4.9	101.02	26.568
	8	4.1~4.4	92.50	24.272
	7	3.6~3.9	83.97	21.976
	6	3.1~3.4	75.77	21.976
	5	2.6~2.9	67.24	20.992
	4	2.1~2.4	59.04	15.416
	3	1.6~1.9	50.84	13.448
	2	1.1~1.4	41.98	11.152
	1	0.6~0.9	33.78	8.856
	0	0.1~0.4	25.26	6.56

# SPEED CHANGE TABLES

## PM605KT

Internal Speed Variation		Analog Voltage	MDR Nominal Speed (FPM)	
SW 1-5	SW 5	Input	55	15
ON	9	9.6~9.9	214.35	56.41
	8	9.1~9.4	196.54	51.72
	7	8.6~8.9	187.59	49.36
	6	8.1~8.4	178.09	46.87
	5	7.6~7.9	169.78	44.68
	4	7.1~7.4	160.60	42.26
	3	6.6~6.9	142.79	37.58
	2	6.1~6.4	134.16	35.31
	1	5.6~5.9	125.42	33.00
	0	5.1~5.4	116.35	30.62
OFF	9	4.6~4.9	107.07	28.18
	8	4.1~4.4	98.54	25.93
	7	3.6~3.9	89.15	23.46
	6	3.1~3.4	80.19	21.10
	5	2.6~2.9	71.45	18.80
	4	2.1~2.4	62.28	16.39
	3	1.6~1.9	53.53	14.09
	2	1.1~1.4	45.01	11.84
	1	0.6~0.9	35.94	9.46
	0	0.1~0.4	26.88	7.07

# SPEED CHANGE TABLES

## PM635KT

Internal Speed Variation		Analog Voltage	MDR Nominal Speed (FPM)		
SW 1-5	SW 5	Input	230	60	16
ON	9	9.6~9.9	854.94	224.98	59.21
	8	9.1~9.4	783.91	206.29	54.29
	7	8.6~8.9	748.18	196.89	51.81
	6	8.1~8.4	710.29	186.92	49.19
	5	7.6~7.9	677.15	178.20	46.89
	4	7.1~7.4	640.56	168.57	44.36
	3	6.6~6.9	569.53	149.88	39.44
	2	6.1~6.4	535.09	140.81	37.06
	1	5.6~5.9	500.22	131.64	34.64
	0	5.1~5.4	464.06	122.12	32.14
OFF	9	4.6~4.9	427.04	112.38	29.57
	8	4.1~4.4	393.09	103.43	27.22
	7	3.6~3.9	355.58	93.57	24.62
	6	3.1~3.4	319.85	84.17	22.15
	5	2.6~2.9	284.98	74.99	19.74
	4	2.1~2.4	248.39	65.37	17.20
	3	1.6~1.9	213.52	56.19	14.79
	2	1.1~1.4	179.51	47.24	12.43
	1	0.6~0.9	143.35	37.72	9.93
	0	0.1~0.4	107.19	28.21	7.42

# INSTALLATION PRECAUTIONS



## IMPORTANT: PLEASE READ BEFORE INSTALLATION

Precaution	Action	Reason
<b>Power supply</b>	If the power supply is not sized appropriately for the number of cards/rollers it provides power to, then a low voltage condition may occur.	<ul style="list-style-type: none"> <li>If the voltage drops below 15V DC and remains low for 1s, then the low voltage error will appear.</li> <li>If the voltage drops below 15V DC five times in 0.5s, then the low voltage error will appear.</li> <li>If the voltage drops below 15V DC less than five times in 0.5s or does not remain low for 1s, the roller may stutter – quickly turning off then on.</li> </ul>
<b>Multiple power supplies</b>	0V line of all power supplies on the same conveyor line (powering the card/rollers, & controls) need to be physically linked together	This completes the signal path from one section of the conveyor (powered by a power supply) to the adjacent section of conveyor (powered by another power supply) and allows for proper communication through the cable and external interfaces.
<b>Voltage drop across the power bus</b>	Use suitable gauge wire in relation to distance and current draw to prevent voltage drop. Operating DC voltage is 24V ±10%	When running long distances from a DC power supply, the voltage drop during motor operation across the power bus may be significant (may drop below 15V). If there is a large enough drop in voltage, the roller(s) may behave in a strange manner. In order to prevent this, a larger gauge wire must be used.
<b>Grounding</b>	Ensure the control card is securely grounded to the conveyor frame. The conveyor frame should also be at the same potential reference as earth ground. Standard grounding practices should be followed.	Static discharge may interfere and damage internal components.
<b>Electrical</b>	24V DC ±10% 4A maximum current limiter (motor lock is 4A) Diode protection for miswiring Sensor power short circuit protection 5A fuse for power supply protection	Improper power will damage the card. The motor/ card should not be subject to locked conditions repeatedly. Internal fuse is not replaceable. If the fuse has blown, more serious damage has occurred within the card/motor
<b>Environment</b>	Ambient temperature is 32~104°F Ambient humidity is < 90% RH Atmosphere has no corrosive gas Vibration is < 0.5G - Indoor use only	Extreme environmental variables may cause poor or no performance and damage the card.
<b>Over-Speeding</b>	Over-speeding of the roller's no-load speed by more than 50% may cause damage.	Back EMF will be generated.

Revision Number	Change
19-0919	Document Created