

IB-E03A, IB-E04F, AND ITOH CONFIGURATOR E/IP SOFTWARE

Operating Instructions



Specifications subject to change without notice

Revised 10/12/2023

SUBJECT	PAGE
Introduction	7
Chapter 1: IB-E Overview	
<ul style="list-style-type: none"> • About the IB-E Module <ul style="list-style-type: none"> ◦ Features ◦ IB-E Models ◦ Conformity 	8
• Operating Environment	9
• Power Requirements	9
• Applicable Power Mollers	9-10
• Hardware Connections <ul style="list-style-type: none"> ◦ Left ("A") Side ◦ Right ("B") Side 	10-11
• Rotary Switches and DIP Switches <ul style="list-style-type: none"> ◦ IP Address Subnet ◦ IP Address Setting (Last Octet) 	12
• LED Indicators <ul style="list-style-type: none"> ◦ Module Status Indicators ◦ LAN and Sensor Status Indicators ◦ Remote (Auxiliary) I/O Status indicators ◦ Motor Activity and Function Indicators 	13-15
Chapter 2: Install the IB-E	
• Mounting the IB-E Module <ul style="list-style-type: none"> ◦ Against a Vertical Surface ◦ Against a Horizontal Surface 	16
• Enclosure Recommendation <ul style="list-style-type: none"> ◦ Recommended General Enclosure Structure 	17
• General Wiring and Precautions <ul style="list-style-type: none"> ◦ Remote (Auxiliary) Inputs ◦ Remote (Auxiliary) Outputs ◦ Overcurrent Protection ◦ Circuit Breaker ◦ Motor Port Discrete Output Wiring 	17-21

SUBJECT	PAGE
Chapter 3: IB-E Networking	
<ul style="list-style-type: none"> • Network Topologies <ul style="list-style-type: none"> ◦ Linear Network Topology ◦ Star Network Topology ◦ Ring Network Topology 	22-23
<ul style="list-style-type: none"> • IB-E Master Mode 	23
<ul style="list-style-type: none"> • IB-E Slave Mode 	24
Chapter 4: Itoh Configurator E/IP	
<ul style="list-style-type: none"> • About the Programming and Configuration Environment 	25
<ul style="list-style-type: none"> • Minimum System Requirements 	25
<ul style="list-style-type: none"> • Installing the Software 	25-26
<ul style="list-style-type: none"> • Windows Firewall (IMPORTANT) <ul style="list-style-type: none"> ◦ Manually Configuring Windows Firewall 	27-33
Chapter 5: Working Within the Environment	
<ul style="list-style-type: none"> • Main Window <ul style="list-style-type: none"> ◦ Main Menu ◦ Icon Toolbar ◦ Project Tree ◦ Program Display 	34-37
<ul style="list-style-type: none"> • Creating a Project 	37
<ul style="list-style-type: none"> • Project Tree <ul style="list-style-type: none"> ◦ Adding a Node ◦ Deleting a Node ◦ Duplicating a Node ◦ Adding a Logic ◦ Deleting a Logic ◦ Duplicating a Logic ◦ Opening Logic ◦ Device List 	38-41
<ul style="list-style-type: none"> • Network 	42
<ul style="list-style-type: none"> • Discovery <ul style="list-style-type: none"> ◦ Connected Modules ◦ Change IP Address 	42-43

SUBJECT	PAGE
• Information	44
• Jog Control	44
• Error Information	45
• Current Monitor	46
• Auto Download	47
• Mechanical Test	48
• Firmware Update	48
Chapter 6: Configuring IB-E	
• Property Setting <ul style="list-style-type: none"> ○ Current Node Properties ○ Current Node Logic ○ Read/Write Controls ○ Properties Window ○ Node Tree 	49-51
• Motor Tab <ul style="list-style-type: none"> ○ Roller Diameter ○ Gear Reduction ○ Roller Speed ○ Speed ○ IB-E Series ○ Sensor Setting ○ Sensor Alarm Setting ○ Motor Type ○ Direction ○ Motor Complementary ○ Gear Stage ○ Mechanical Brake ○ Brake (Electric) ○ Motor Port Setting ○ Motor Lock Timeout ○ Servo Brake Current Limit ○ Motor Current Limit ○ Circuit Board Thermal Protection 	51-56

TABLE OF CONTENTS

SUBJECT	PAGE
<ul style="list-style-type: none"> • Error/Network Tab <ul style="list-style-type: none"> ◦ Thermal ◦ Motor Lock ◦ Motor Disconnected ◦ Receive and Transmit Nodes 	56-58
• Acceleration/Deceleration Tab	58-59
• Timer Tab	59
• Counter Tab	59
• Pulse Counter Tab	60
• Master/Slave	60-62
Chapter 7: Logic Programming	63
• Program Display	
• Command Input <ul style="list-style-type: none"> ◦ Function Select ◦ Function ◦ Arguments ◦ Comment ◦ Address and Comments 	63-65
• Boolean Functions <ul style="list-style-type: none"> ◦ Inputs ◦ Outputs ◦ Logic Operations 	65-68
• Action Functions <ul style="list-style-type: none"> ◦ Timers ◦ Counters ◦ Pulse Counters 	69-73
• Data Handling <ul style="list-style-type: none"> ◦ Move Functions ◦ Compare Functions 	73-79
• Motor Positioning	79-81
• Build	81

SUBJECT	PAGE
Chapter 8: Troubleshooting	82
• Motor Drive Error Conditions	
• Physical Behavior	83-84
• Software Issues	84
• Module Reset	84
Chapter 9: PLC Connection	85
• Overview	
• Rockwell Automation Processor	
◦ Add-On Profile	85-87
◦ Generic Ethernet Module	
• Other Ethernet/IP Processors	87

PREFACE:

- This manual describes the configuration and operation settings for the IB-E03A and IB-E04F.
- Because of the similarity between the models, most photos and drawings reference the IB-E01 (discontinued). Where necessary, the specific models and/or differences have been identified. Otherwise, “IB-E” will be used to generally identify any of the modules.
- This document also explains the use of the configuration and ladder diagram-editing environment, the ITOH Configurator E/IP (ICE) software.

UPDATED INFORMATION:

- This document may contain new and/or updated information.
- Review the list below for any changes.

Change	Revision Date	Page
Initial document	201404-001	n/a
Added IB-E03A and IB-E04F references	201408-001	multiple

1. IB-E OVERVIEW

ABOUT THE IB-E MODULE:

- The IB-E is a dual 24V brushless DC motor driver module that is compact, network-ready, configurable, and programmable.

FEATURES:

- Two brushless DC motor drivers
 - IB-E03A: 4A max per driver
 - Two non-replaceable 7A fuses, one for each driver, to protect supply line
 - IB-E04F: 7A max per driver
 - One non-replaceable 15A fuse, for the drivers, to protect supply line
- Built-in motor overload protections
- Two powered connections for sensors
- Three isolated auxiliary inputs
- Five isolated auxiliary outputs
 - Two at 1A (max) each
- Motor lifetime data
- DLR (device level ring) applicable
- 2-port built-in Ethernet switch (based on RA switch technology)

IB-E MODELS:

- When ordering, the sensor signal type must be indicated for factory settings of the IB-E

PNP	NPN
IB-E03A-P	IB-E03A-N
IB-E04F-P	IB-E04F-N

CONFORMITY:

- CE Marking
 - Relevant EC Directives: EMC Directive 2004/108/EC
 - Applied Standards: EN55011-1:1998 + A2:2002 (Class A, Emission), EN61000-6-2:2005 (Immunity)
- Immunity EN61000-6-2/2001 Industrial environment
 - IEC 61000-4-2 Electrostatic discharge immunity, Level 4, Criteria B
 - IEC 61000-4-3 Radiated, radio-frequency, electromagnetic field immunity, Criteria A
 - IEC 61000-4-4 Electrical fast transient/burst immunity, Criteria B
 - IEC 61000-4-5 Surge immunity, Criteria B
 - IEC 61000-4-6 Immunity to conducted disturbances, induced by radio-frequency fields, Criteria A
 - IEC 61000-4-8 Power frequency magnetic field immunity, Criteria A
- Emission EN61000-6-4/2001 Industrial environment
 - VCCI Radiated interference, Class A
 - VCCI Main terminal interference voltage, Class A
- UL/cUL – Recognized Component (IB-E03A & IB-E04F)
- ODVA – EtherNet/IP Conformance Tested

1. IB-E OVERVIEW

OPERATING ENVIRONMENT:

Conditions		Notes
Ambient Temperature	-20 to 40°C (-4 to 104°F)	No condensation, water, frost, or ice
Humidity	≤ 90% Relative Humidity	
Atmosphere	No corrosive gas	
Vibration	≤ 1.0G	
Installation	Indoor	
Pollution Level	2	Conforming to IEC60640-1 and UL840
Overvoltage Category	2	

POWER REQUIREMENTS:

Item	Specification
Input Power	24V DC (+/- 5%)
Typical Loaded Current Draw Per Motor* for IB-E03A	2~3A - Motor A 2~3A - Motor B
Maximum Current Draw Per Motor for and IB-E03A	4A - Motor A 4A - Motor B
Typical Loaded Current Draw Per Motor* for IB-E04F	3~4A - Motor A 3~4A - Motor B
Maximum Current Draw Per Motor for IB-E04F	7A - Motor A 7A - Motor B
Maximum Current Draw Per Remote (Auxiliary) Output	1A - Remote output 1 1A - Remote output 2 20mA - Remote output 3 20mA - Remote output 4 20mA - Remote output 5

* Actual current draw is dependent on load (size and weight) and motorized roller model used

- Note: The Remote (Auxiliary) Outputs are isolated from the IB-E power. Therefore, a separate 24V DC power source may be used. If not, the Remote Output current draw should be factored into the IB-E's overall current draw when used.

APPLICABLE POWER MOLLERS (MOTORIZED ROLLERS):

FOR IB-E03A:

Standard	With Brake Option
PM486FE	PM486FE-BR
PM486FS	PM486FS-BR
PM486FP	PM486FP-BR
PM570FE	PM570FE-BR
PM605FE	PM605FE-BR
PM635FS	PM635FS-BR

* IB-E03A is designed to work with both our standard models and brake models. The (mechanical) brake option requires a 10th pin for the brake coil. Therefore, standard model rollers will need to have either a 10-pin connector on the motor cable or a 9-to-10-pin extension cable

1. IB-E OVERVIEW

APPLICABLE POWER MOLLERS FOR IB-E03A (CONTINUED)

Example Nomenclature for Models

Standard (requiring extension cable)	PM486FE-60-544-D-024-P2
Standard with 600mm cable and a 10-pin connector	PM486FE-60-544-D-024-Z060-P2
Brake with 600mm cable	PM486FE-60-544-D-024-BR-C060-P2

APPLICABLE POWER MOLLERS FOR IB-E04F:

Standard*
PM486FH
PM570KT
PM605KT
PM635KT





Example Nomenclature for Models

Standard (12-pin connector)	PM635KT-16-544-D-024
-----------------------------	----------------------

* There are no (mechanical) brake models available for the IB-E04F

HARDWARE CONNECTIONS:

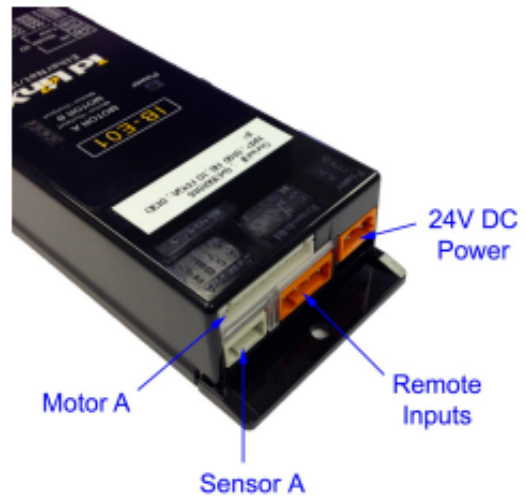

LEFT "A" SIDE:

Connection	Pin Outs	Description
Motor A		Brushless DC Driver When configured as a discrete output (NPN, sinking, only): 3 - Discrete output U (IB-E04F pins 3 & 4) 4 - Discrete output V (IB-E04F pins 5 & 6) 5 - Discrete output W (IB-E04F pins 7 & 8) See "Precaution: Motor Port Discrete Output Wiring" below Connector for wiring: JST XHP-10 (IB-E04F XHP-12) Included with motorized roller
Sensor A		1 - 24V DC (550mA max) 2 - Sensor input (35mA max) 3 - 0V 4 - Sensor alarm input (35mA max) Signal types are set as PNP or NPN from factory. Noted as a "-P" or "-N", respectively (e.g. IB-E03A-P) Connector for wiring: WAGO 733-104
Remote Inputs (auxiliary)		1 - Remote input 1 2 - Remote input 2 3 - Remote input 3 4 - Common (24V DC for NPN or 0V for PNP) Connector for wiring: WAGO 734-304
24V DC Power		Input Power 1 - 0V 2 - 24V DC Connector for wiring: WAGO 231-302/026-000



1. IB-E OVERVIEW

RIGHT "B" SIDE:

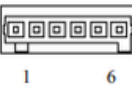
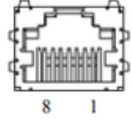
Connection	Pin Outs	Description
Motor B		<p>Brushless DC Driver When configured as a discrete output (NPN, sinking, only): 3 - Discrete output U (IB-E04F pins 3 & 4) 4 - Discrete output V (IB-E04F pins 5 & 6) 5 - Discrete output W (IB-E04F pins 7 & 8) See "Precaution: Motor Port Discrete Output Wiring" below)</p> <p>Connector for wiring: JST XHP-10 (IB-E04F XHP-12) Included with motorized roller</p>
Sensor B		<p>1 - 24V DC (550mA max) 2 - Sensor input (35mA max) 3 - 0V 4 - Sensor alarm input (35mA max)</p> <p>Signal types are set as PNP (+24V DC) or NPN (0V) signals. In the normal state, the input pins have a +12V DC reference</p> <p>Connector for wiring: WAGO 733-104</p>
Remote Outputs (Auxiliary)		<p>1 - Remote output 1, 1A max 2 - Remote output 2, 1A max 3 - Remote output 3, 20mA max 4 - Remote output 4, 20mA max 5 - Remote output 5, 20mA max 6 - Common (24V DC for PNP or 0V for NPN)</p> <p>Connector for wiring: WAGO 734-206</p>
LAN (1 & 2)		<p>1 - Tx + 2 - Tx - 3 - Rx + 4 - n/a 5 - n/a 6 - Rx - 7 - n/a 8 - n/a</p> <p>Connector for wiring: RJ-45</p>

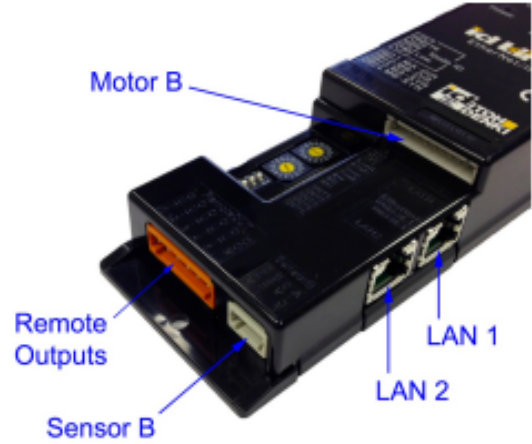

1. IB-E OVERVIEW

ROTARY SWITCHES AND DIP SWITCHES:

Switch	Position	Description
IP Address High Byte	0 ~ F	Hexadecimal setting of IP address' last octet. 192.168.1.xxx Example 1: High Byte: "0" Low Byte: "1" Hexadecimal value "01" = 1 (decimal) IP Address: 192.168.1.1
		Example 2: High Byte: "A" Low Byte: "7" Hexadecimal value "A7" = 167 (decimal) IP Address: 192.168.1.167
DIP 1	OFF	Default
	ON	Motor A's direction is opposite of configuration, reversed
DIP 2	OFF	Default
	ON	Motor B's direction is opposite of configuration, reversed
DIP 3	OFF	Default
	ON*	Motor A operates when Motor B operates, synchronized
DIP 4	OFF	Default
	ON*	Motor B operates when Motor A operates, synchronized



* If both DIP switch 3 and 4 are ON, the IB-E is set to factory reset mode. Refer to Chapter 8 – Troubleshooting for more information.

IP ADDRESS SUBNET:

- Default: 192.168.1.xxx

If a different subnet for the IP address is needed, different from the default 192.168.1.xxx, it can be changed using the Itoh Configurator for EtherNet/IP (ICE).

IP ADDRESS SETTING (LAST OCTET):

- The rotary switches set the last octet of the IB-E's IP address. There are 16 positions (hexadecimal base) for each rotary switch.
- The following table is available to assist in determining the decimal equivalent of the hexadecimal rotary switch positions.
- Using the decimal values, the last octet can be calculated.



Base	High Byte	Low Byte	Last Octet
Hexadecimal	C	A	CA
Decimal	192	10	202

High Byte		Low Byte	
Position	Base Decimal Value	Position	Base Decimal Value
0	0	0	0
1	16	1	1
2	32	2	2
3	48	3	3
4	64	4	4
5	80	5	5
6	96	6	6
7	112	7	7
8	128	8	8
9	144	9	9
A	160	A	10
B	176	B	11
C	192	C	12
D	208	D	13
E	224	E	14
F	240	F	15

1. IB-E OVERVIEW

LED INDICATORS

- See Chapter 8 for troubleshooting error statuses.

MODULE STATUS INDICATORS:

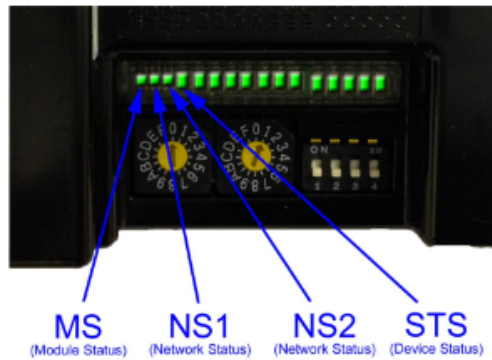

LED	LED Indication Pattern		Description
	Green	Red	
MS	OFF	OFF	No network power
	ON	OFF	Normal operation
	ON	Flash (1Hz)	No setting on device
	OFF	Flash (1Hz)	Network error at LAN 1 or LAN 2
	OFF	ON	Network error at LAN 1 and LAN 2
	Flash (1Hz)	Flash (1Hz)	Boot up sequence
NS1 & NS2*	OFF	OFF	No communication
	Flash (1Hz)	OFF	Normal operation
	ON	OFF	I/O connection
	OFF	Flash (1Hz)	I/O connection timeout error
	OFF	ON	Duplicate IP address error
	Flash (1Hz)	Flash (1Hz)	Boot up sequence
STS	ON	-	Power ON on Network PCB
	Flash (6Hz)	-	Low voltage (<20V DC) error
	Flash (1Hz)	-	Firmware updating
	OFF	-	No power on network PCB

*NS2 is only on the IB-E01

1. IB-E OVERVIEW

LAN AND SENSOR STATUS INDICATORS:

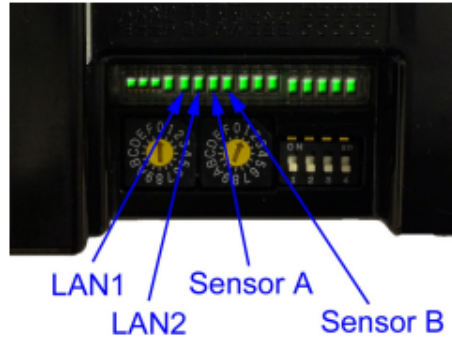

LED	LED Indication Pattern		Description
	Green	Red	
LAN1 & LAN2	Flash	-	Active LAN Communication
	OFF	-	No LAN Communication
SenA & SenB	ON	-	Sensor input is active
	OFF	-	No sensor input

REMOTE (AUXILIARY) I/O STATUS INDICATORS:

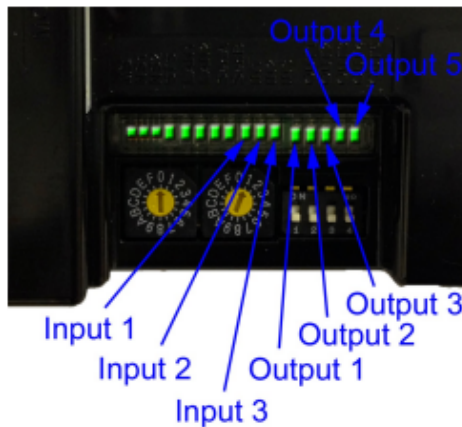

LED	LED Indication Pattern		Description
	Green	Red	
IN1 ~ IN3	ON	-	Remote input is active
	OFF	-	No remote input
OUT1 ~ OUT5	ON	-	Remote output is active
	OFF	-	No remote output

1. IB-E OVERVIEW

MOTOR ACTIVITY AND FUNCTION INDICATORS:

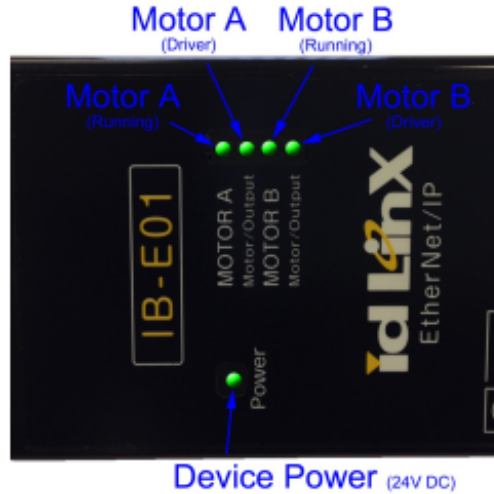

LED	LED Indication Pattern		Description
	Green	Red	
Power	ON	-	Normal, power is on
	OFF	-	No power to device
Motor/Output	ON	-	24V brushless DC driver
	OFF	-	Discrete outputs
Motor A & Motor B	OFF	OFF	Motor is not running
	Flash (1Hz)	OFF	Motor is running, CW
	ON	OFF	Motor is running, CCW
	OFF	Flash (6Hz)	Low voltage error
	OFF	Flash (1Hz)	Motor unplugged error
	ON	Flash (1Hz)	Motor locked error
	OFF	ON	Thermal error
	ON	2 x Flash (0.6Hz)	Back EMF error
	Alternating (1Hz)		JAM error*
	Alternating (6Hz)		Sensor Timer error*

* These errors are triggered by outputs from the internal logic.

2. INSTALLING THE IB-E

MOUNTING THE IB-E MODULE:

- IB-E can be installed in any position (vertical, horizontal, upside-down, etc.) as shown below.
 - Mounting screw pitch – 210mm (8.27in)
 - Recommended screw for mounting – Cross-recessed head screw M4
 - Tightening torque of mounting screw – 0.74Nm (7.5kgf·cm, 6.5lb·in)

⚠ WARNING
 Avoid electrical shock or shorting.
 Make sure that the mounting screws do not come in contact with any of the connectors

AGAINST A VERTICAL SURFACE:

- Right-side up

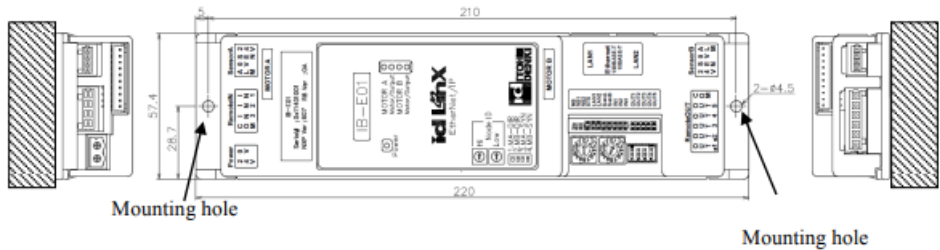

- Up-side down

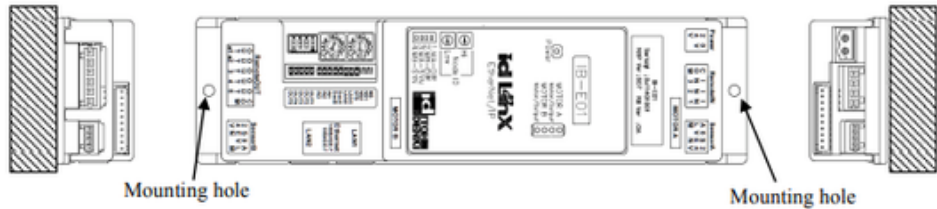

AGAINST A HORIZONTAL SURFACE:

- Above



- Below



⚠ DANGER
 Avoid possible burns.
 Motor driver circuits produce heat. Allow product to cool before handling.

2. INSTALLING THE IB-E

ENCLOSURE RECOMMENDATION:

- The devices described in this manual are defined as “Open Type”, complying with UL508C standard. Therefore, in order to conform to UL, the devices must be installed within an enclosure, which requires tooling to open, in order to restrict access inside and prevent unintended contact failure.

RECOMMENDED GENERAL ENCLOSURE STRUCTURE:

- For general motorized roller conveyors, the driver card and its wiring must be protected by an enclosure, which may be constructed using a conveyor frame and frame cover, as noted in the drawing below. A tool would be necessary in order to remove the frame cover. The protective level of this enclosure must conform to UL50 Type 1 or greater.

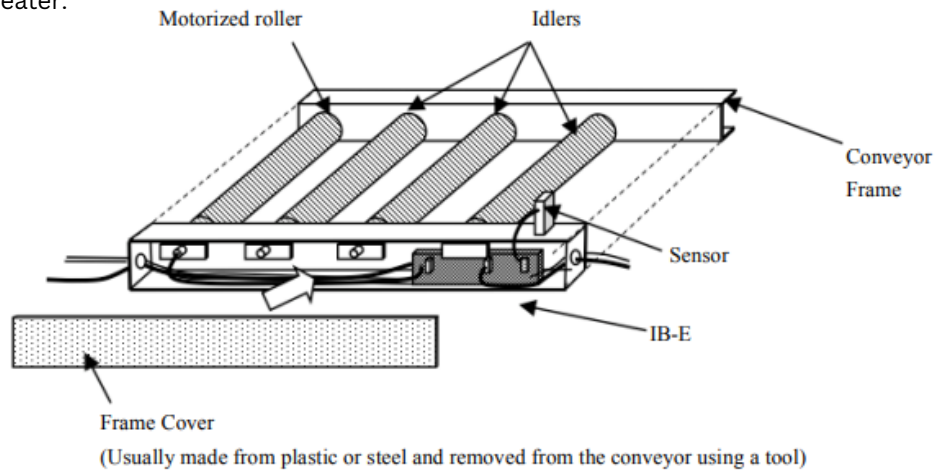

GENERAL WIRING AND PRECAUTIONS:

- For specific connector pin outs, refer to Chapter 1 – Hardware Connections.

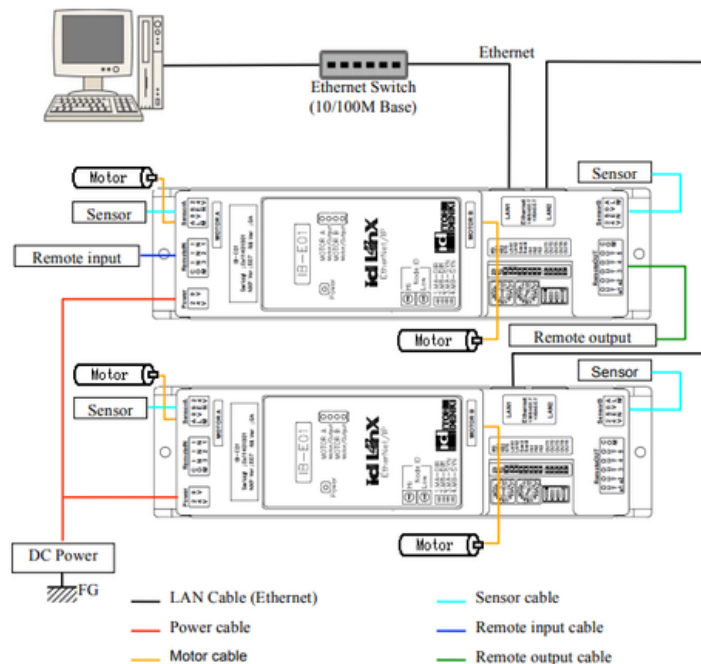

2. INSTALLING THE IB-E

REMOTE (AUXILIARY) INPUTS:

- Card power must be 18V DC to 30V DC for the remote input circuit to operate.

PNP Wiring (Sinking Input, 0V)

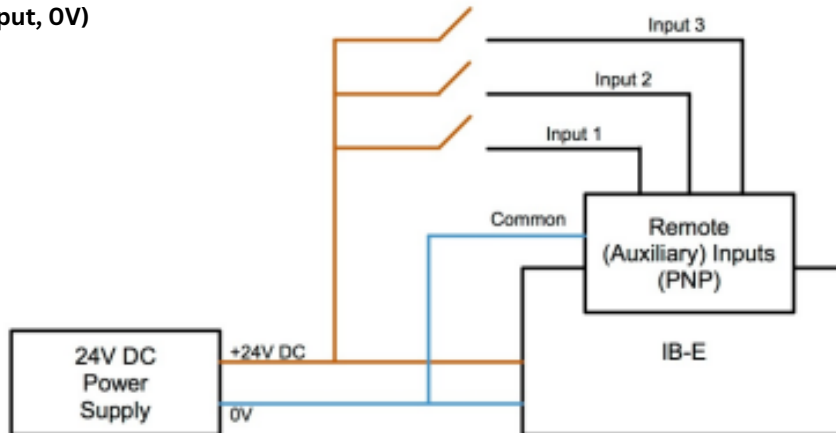

NPN Wiring (Sourcing Input, +24V DC)

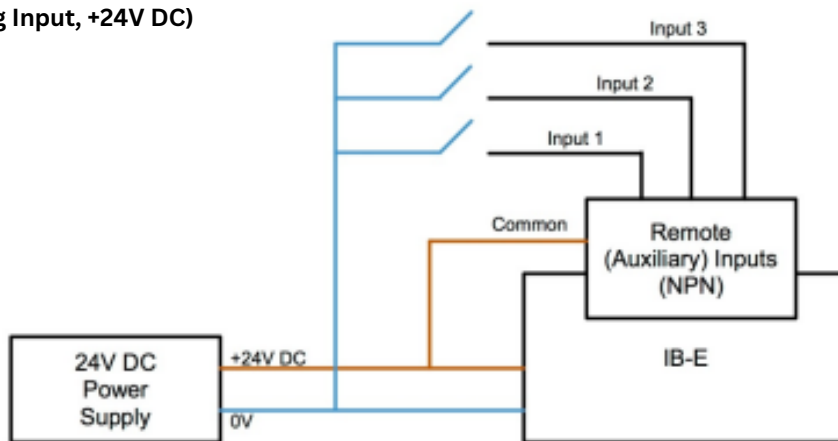

2. INSTALLING THE IB-E

REMOTE (AUXILIARY) OUTPUTS:

- Card power must be 18V DC to 30V DC for the remote output circuit to operate.
 - 1A maximum current for outputs #1 and #2
 - 20mA maximum current for outputs #3 through #5

PNP Wiring (Sinking Input, 0V)

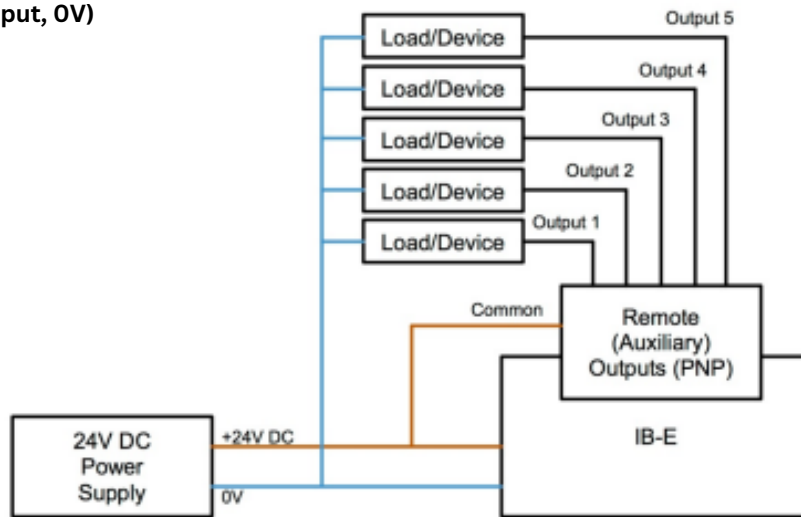

NPN Wiring (Sourcing Input, +24V DC)

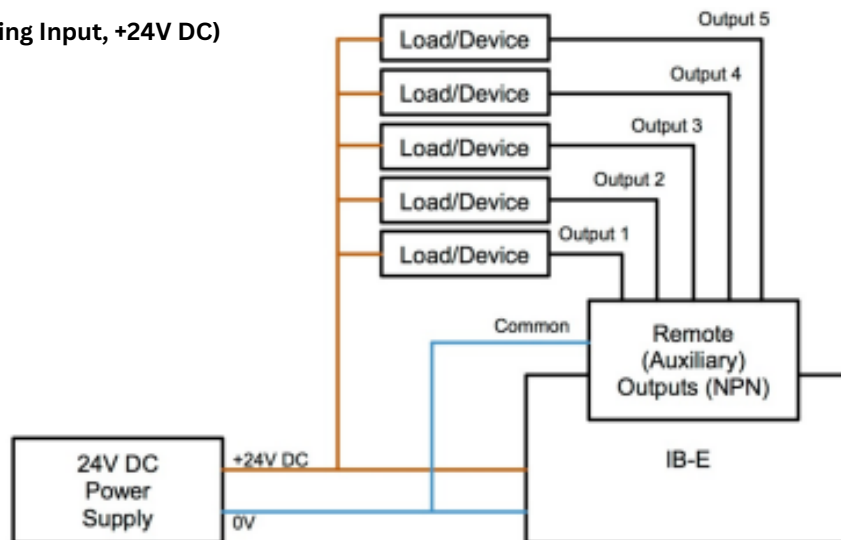

2. INSTALLING THE IB-E

OVERCURRENT PROTECTION:

- If a DC power source, or power supply, requires overcurrent protection to comply with a particular safety standard (i.e. UL60950-1, etc.), then install the overcurrent protection device as shown in the diagram below. If no such protection is required, then this is not necessary.

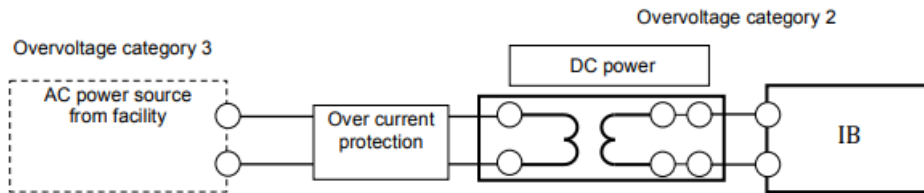

CIRCUIT BREAKER:

- When an error arises on the IB-E, it may be necessary to turn off the DC power to address the issue. If that is the case, an option may be to install a circuit breaker as shown in the diagram below. If the status messages are monitored by an upper level control device (i.e. PC, PLC, etc.), then a circuit breaker may be controlled by such a device. If the messages are not monitored, then the DC circuit may also need an overload detection device added (or built in to the circuit breaker).

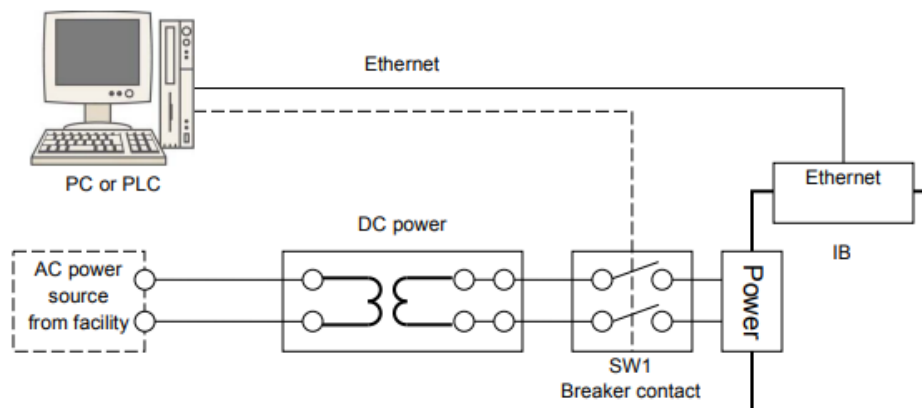

MOTOR PORT DISCRETE OUTPUT WIRING:

- Only NPN output signals are available for the motor port's discrete outputs (remote port).
- When the IB-E is powered OFF, a "live" discrete output is present from the motor port if ALL of the following are true:
 - The motor port is configured as a discrete output (refer to the "Driver Configuration" section).
 - A load/device is connected to a live 24V DC line and to the motor port discrete output.
 - The 24V DC power source of the load/device is common with the 24V DC power source of the IB-E. 0V lines are the same or connected together.
 - The common 0V line is connected to the IB-E.

Example 1, Not Recommended
Single Power Supply:

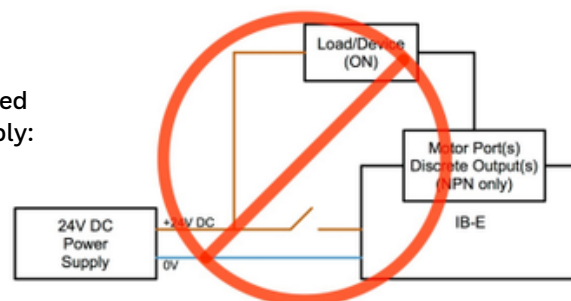

2. INSTALLING THE IB-E

MOTOR PORT DISCRETE OUTPUT WIRING (CONTINUED):

Example 2, Not Recommended
Two Power Supplies:

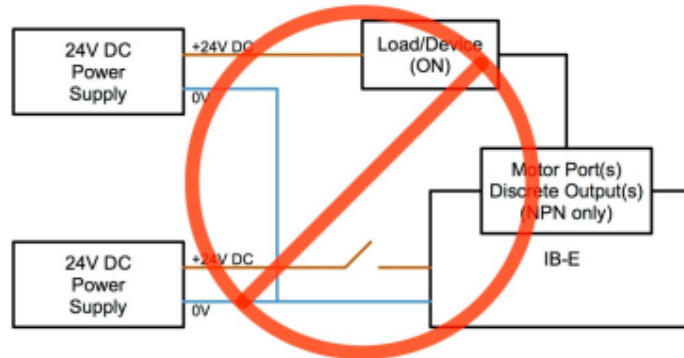

Example 3, OK
Single Power Supply:

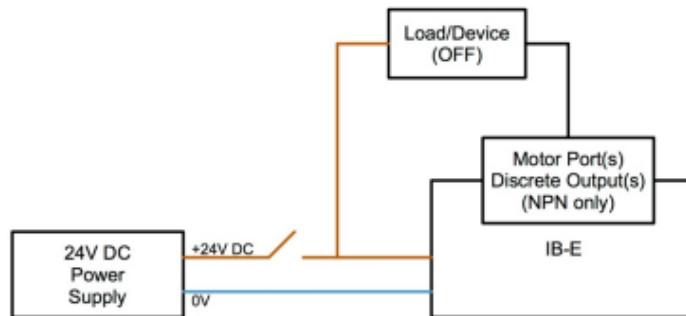

Example 4, OK
Two Power Supplies:

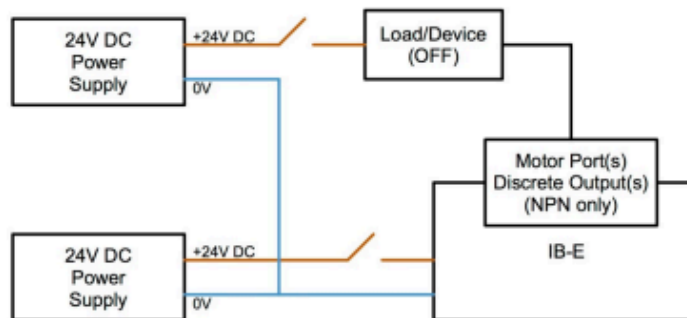

■ Note: Examples 3 & 4 are just a few ways that the load/device may be wired and powered, other methods do exist.

3. IB-E NETWORKING

NETWORK TOPOLOGIES:

- A wide variety of Ethernet network topologies are available, due to the IB-E’s built-in 2-port Ethernet switch. Typical topologies would include linear, star, and ring. However depending on the topology, other hardware may be necessary to complete communication.
- In order to configure parameters (motor speed, acceleration, etc.) and download logic into the IB-E modules, an Ethernet connection to the modules is required and the PC must be on the same subnet as the modules (default 192.168.1.xxx).
- NOTE: In order to maintain proper communications speeds, any device (i.e. controller, PLC, etc.) connected to the IB-E’s Ethernet port(s) must be set to “Auto-Negotiate”. The only Ethernet communication setting available on the IB-E is Auto-Negotiate.

LINEAR NETWORK TOPOLOGY:

- A linear network topology utilized the 2-port Ethernet switch built-in to the IB-E. From the PC, an Ethernet cable is connected to one an IB-E at either end. Then, an Ethernet cable is connected module to module.

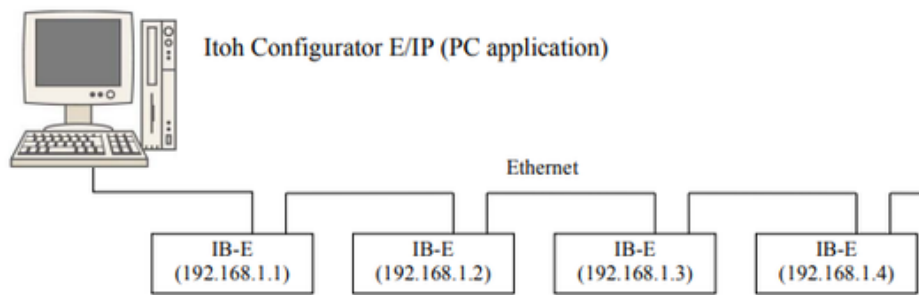

STAR NETWORK TOPOLOGY (REQUIRES ETHERNET SWITCH):

- A star network topology has one point of connection to each device on the network. Each of these connections returns to a common Ethernet switch.

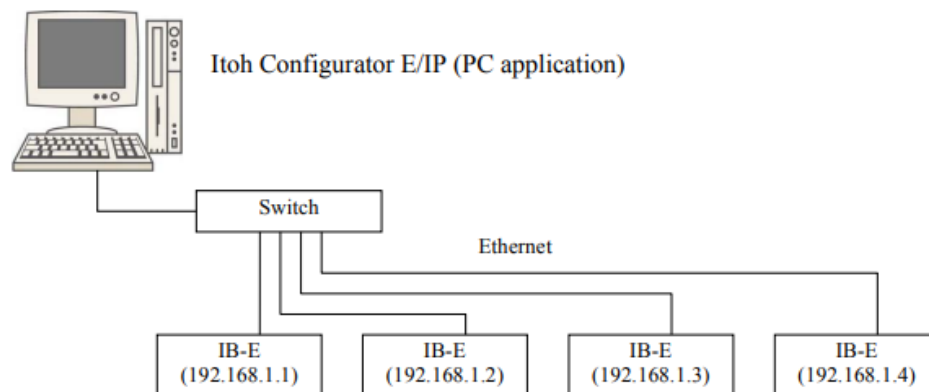

3. IB-E NETWORKING

RING NETWORK TOPOLOGY (REQUIRES ETHERNET/IP RING SUPERVISOR):

- A ring network topology is similar to the linear topology with the addition of another Ethernet connection between the beginning and ending devices. A special module called a “Ring supervisor” is needed in order to utilize this topology, which is based on EtherNet/IP. The advantage to this topology is the redirection of network communication in the event of a break in communication between two modules.

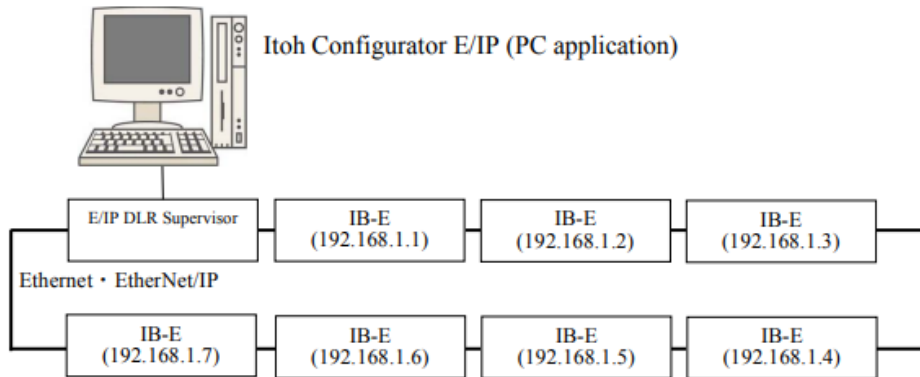

IB-E MASTER MODE:

- Master Mode is an operational parameter set by ICE, which allows the IB-E to function using the internal logic created by the ladder diagram editor in ICE. This mode may also be referred to as “stand alone”, since it is able to operate independently from any other IB-E or EtherNet/IP (implicit messaging) controller (PLC). Depending on the logic written for this mode, the IB-E may be able to function even after disconnecting it from the network.

Example 1 – IB-E modules set as masters communicating with each other:

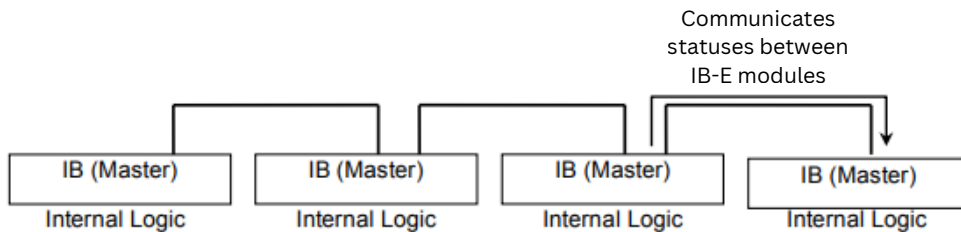

Example 2 – IB-E modules set as masters, handshaking statuses with an EtherNet/IP controller

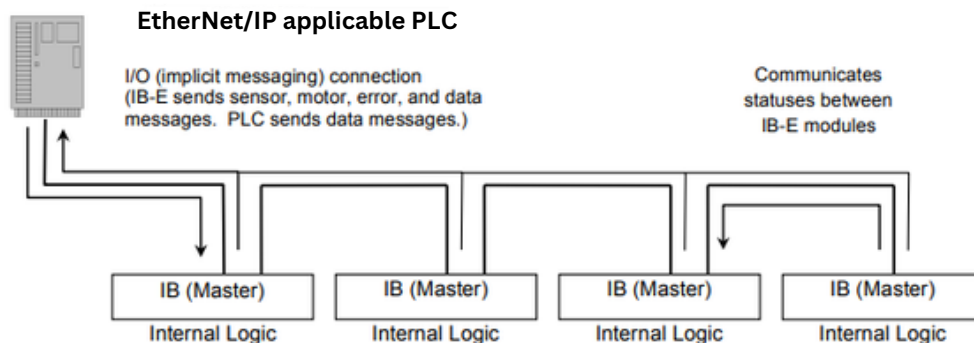

3. IB-E NETWORKING

IB-E SLAVE MODE:

- Slave Mode is an operational parameter set by ICE, which allows the IB-E to function under the direct command of another IB-E module set as a master or an EtherNet/IP (implicit messaging) controller (PLC). Internal logic (if any) in the slave IB-E is ignored. However, parameters (motor speed, acceleration, etc.) of the slave IB-E are still configured independently from the master IB-E.

Example 1 – IB-E modules set up as slaves to an IB-E module set up as a master

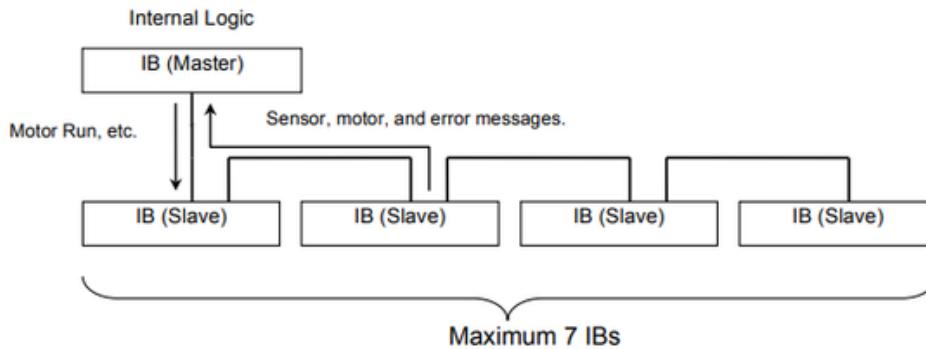

Example 2 – IB-E modules set up as slaves to an EtherNet/IP controller

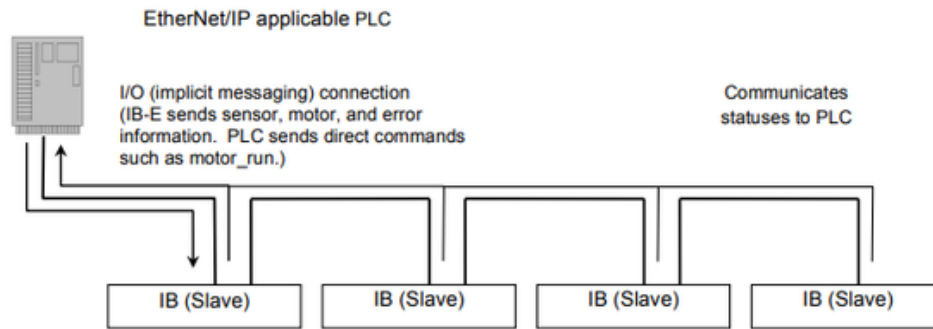

4. ITOH CONFIGURATOR E/IP

ABOUT THE PROGRAMMING AND CONFIGURATION ENVIRONMENT:

- The Itoh Configurator for E/IP (ICE) is used to create projects, configure user parameters, and write, build (compile), and download, the ladder logic into the IB-E.

MINIMUM SYSTEM REQUIREMENTS:

Operating System	Microsoft Windows XP, 7, and 8
Processor	Pentium4 2.0GHz or better
RAM	1GB or more
.NET Framework	Version 3.5 or later
Resolution	1024×768
Capacity	Ensure there is enough space on the drive to create and save projects.

INSTALLING THE SOFTWARE:

- Browse to the location where the installation file is saved. Double click it to begin the installation process.

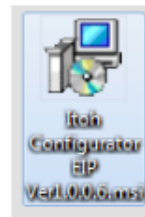

- Follow the prompt to setup installation:

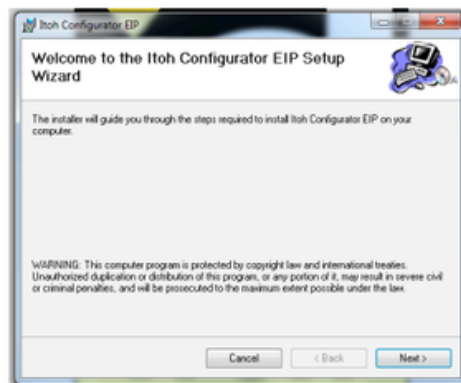

- If a different installation folder is desired, insert that location here:
- Disk Cost will show the space this program will occupy on the hard drive
- If there are multiple users on the computer to which this program is being installed, and these users would need access to this program, selecting “Everyone” will allow every user to execute the program.
- Note: Each user will have a unique Project folder and files.

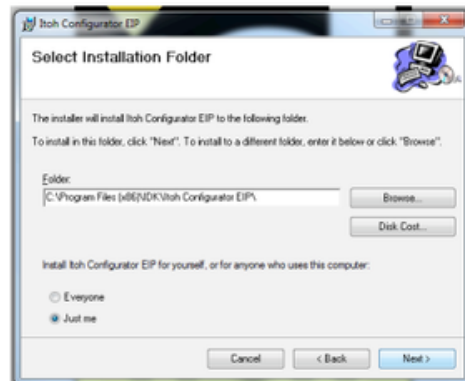

4. ITOH CONFIGURATOR E/IP

INSTALLING THE SOFTWARE (CONTINUED):

- Follow the prompt to begin the installation:

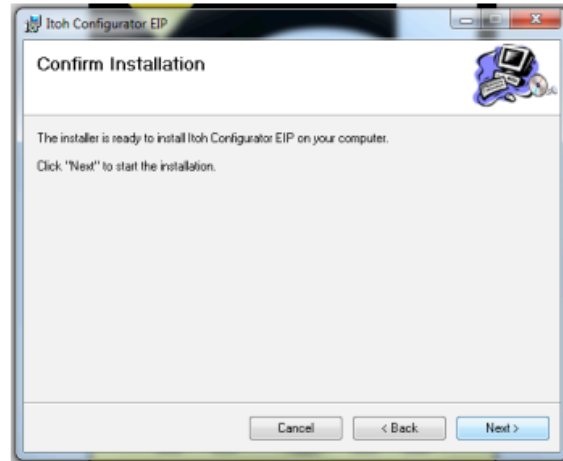

- Accept the changes to the computer:

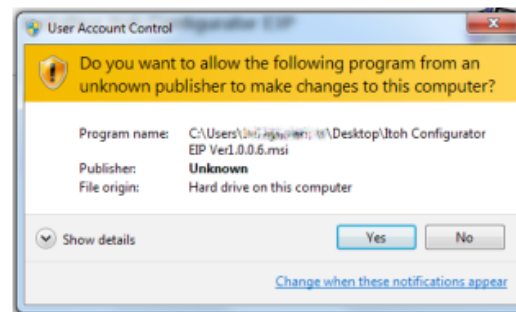

- Follow the prompt to complete the installation:

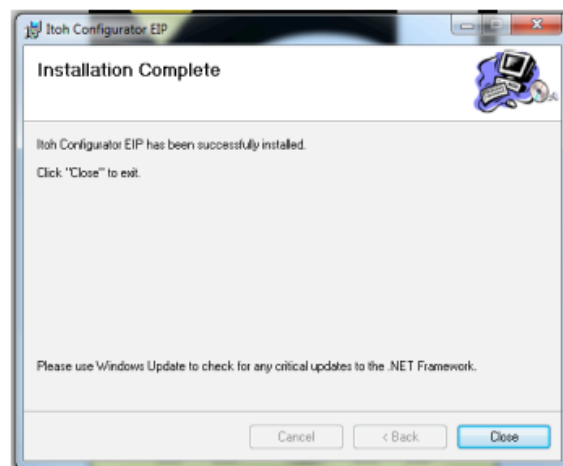

4. ITOH CONFIGURATOR E/IP

WINDOWS FIREWALL CONFIGURATION (IMPORTANT):

- The following steps work the first time ICE is opened while connected to a network. It is the easiest way to configure Windows Firewall, however it is not the only method.
- When connected to a network (LAN/WLAN), launch Itoh Configurator E/IP

- Double-click the Desktop Shortcut



- Open the “Discovery” window

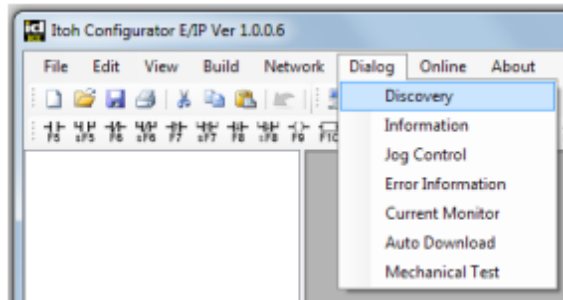

- The IP address shown in the Discovery window should be the PC's IP address (NOT the loopback address “127.0.0.1”)

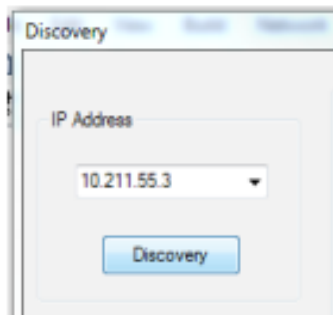

- Click on the “Discovery” button

- The Windows Firewall alert will show.
- Make sure both Private and Public networks are selected, and then click on “Allow access”



- The Windows Firewall is now configured

4. ITOH CONFIGURATOR E/IP

MANUALLY CONFIGURING WINDOWS FIREWALL:

- 1. Click on the Windows Start button, and then click on “Control Panel” in the Start Menu

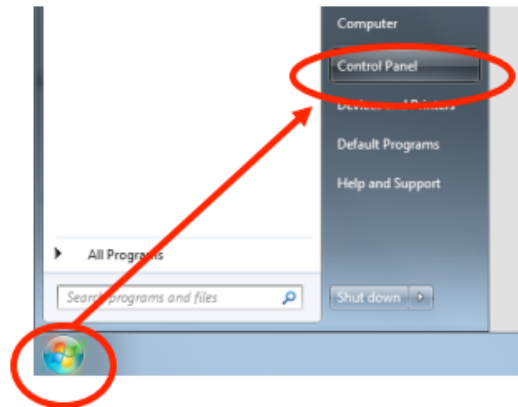

- 2. Click on “System and Security”

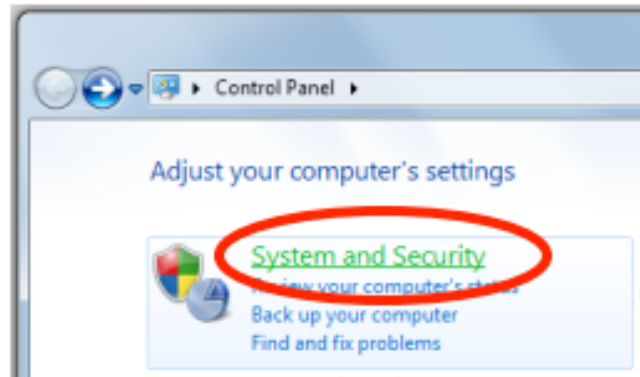

- 3. Click on “Windows Firewall”

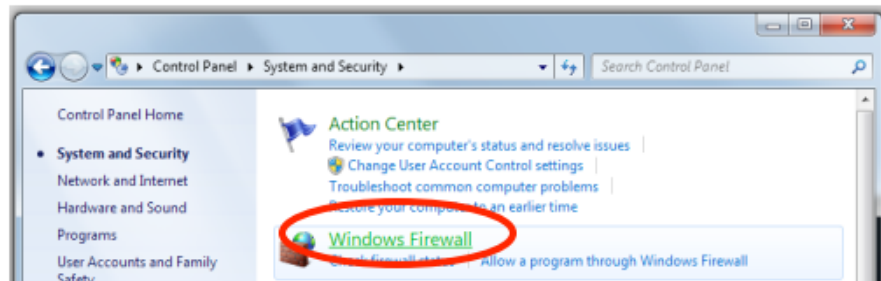

- 4. Click on “Advanced settings” in the left-hand column

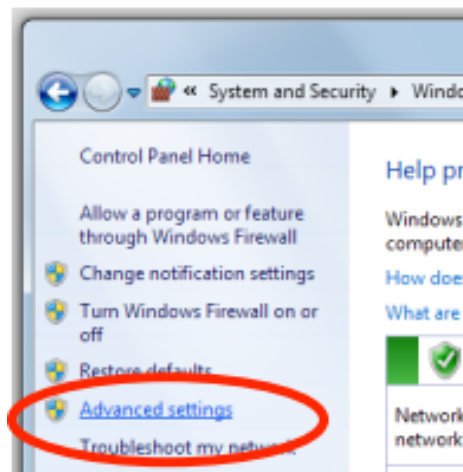

4. ITOH CONFIGURATOR E/IP

- 5. Click on “Inbound Rules” in the left-hand column

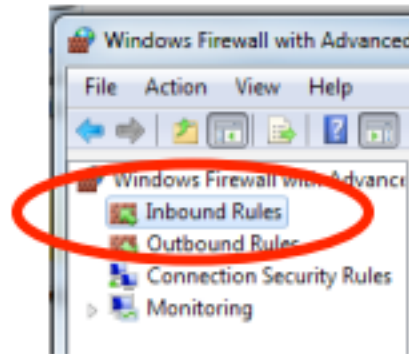

Creating a New Rule

When creating a Windows Firewall rule, begin with Step 1.
When modifying a Windows Firewall rule, skip to Step 9.

- 1. Click on “New Rule...” in the right-hand column

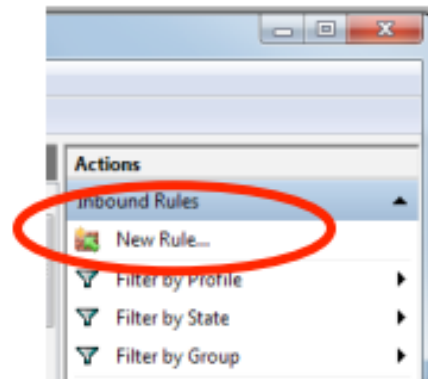

- 2. Select “Program”, and then click “Next”

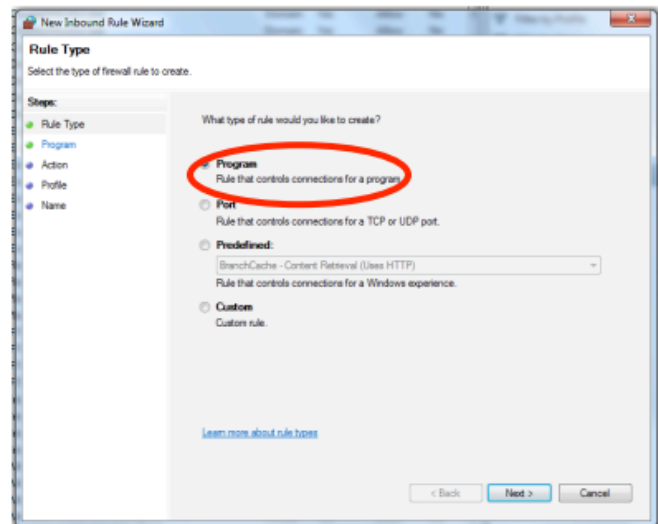

4. ITOH CONFIGURATOR E/IP

- 3. Browse to the program, and then click on “Next”

“C:\Program Files (x86)\Ith\Itoh Configurator EIP\LDProgrammer.exe”

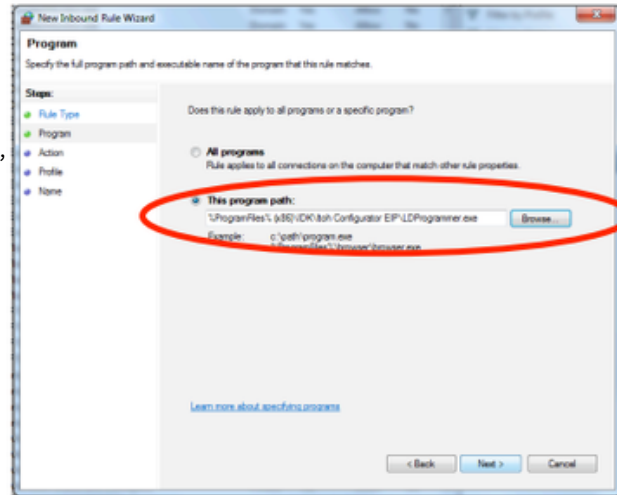

- 4. Select “Allow the connection”, and then click “Next”

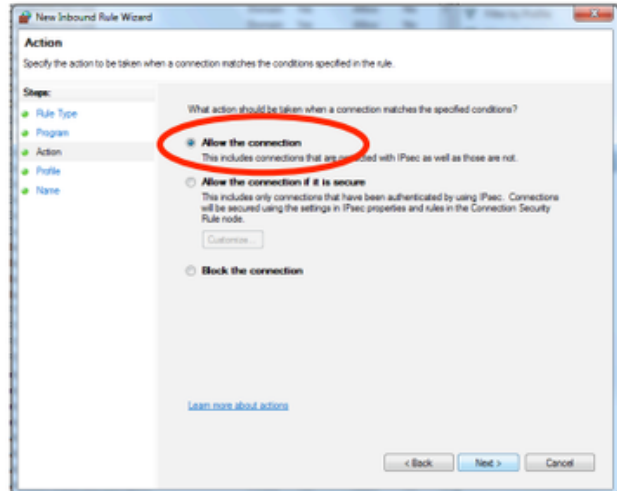

- 5. Select “Private” and “Public”, and then click “Next”

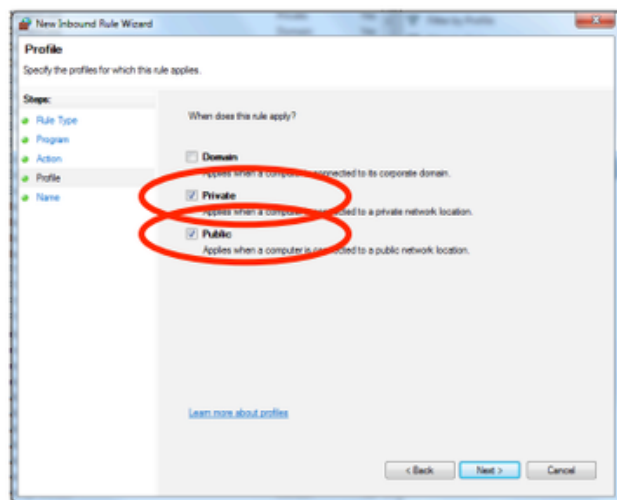

4. ITOH CONFIGURATOR E/IP

- 6. Name the rule “Itoh Configurator E/IP”, and then click “Finish”

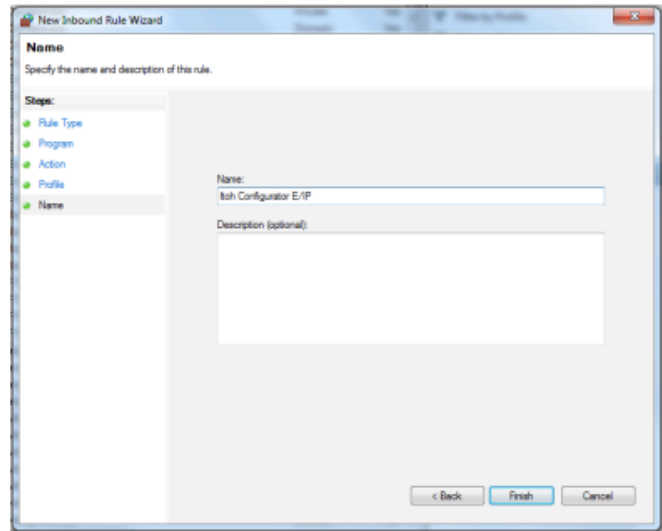

- 7. Select the newly created rule from the middle column

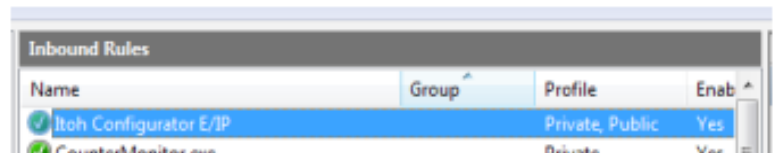

- 8. Click on “Copy” from the right-hand column

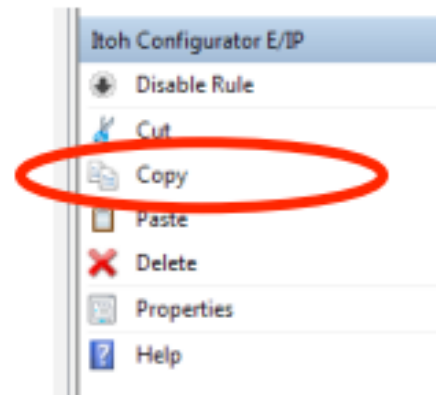

- 9. Select one of the “Itoh Configurator E/IP” rules

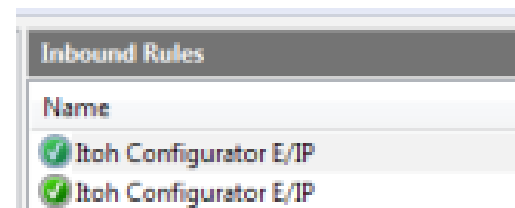

- If the Windows Firewall setting was configured, but both “Public” and “Private” network selections were not checked when the alert was displayed, the settings can be changed manually. Skip to step 14. Otherwise, continue to Step 10.

4. ITOH CONFIGURATOR E/IP

10. Click on the “Protocols and Ports” tab

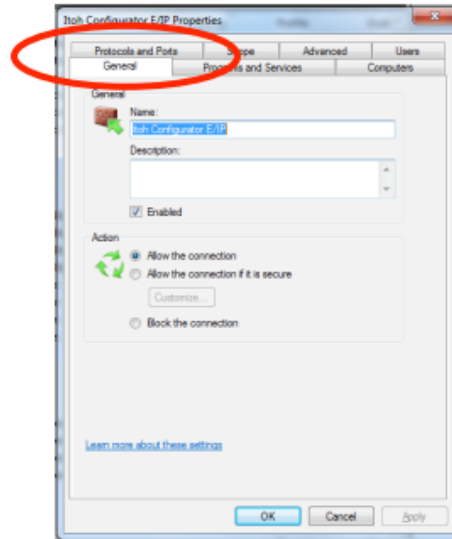

11. Select “TCP” from the “Protocol type” drop down list, and then click “OK”

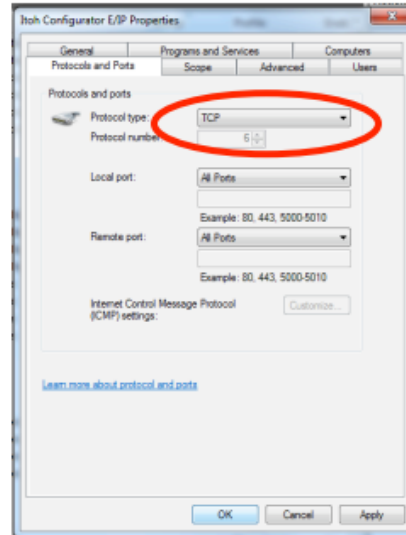

12. Repeat Steps 9 and 10 for the other “Itoh Configurator E/IP” rule

13. Select “UDP” from the “Protocol type” drop down list, and then click “OK”

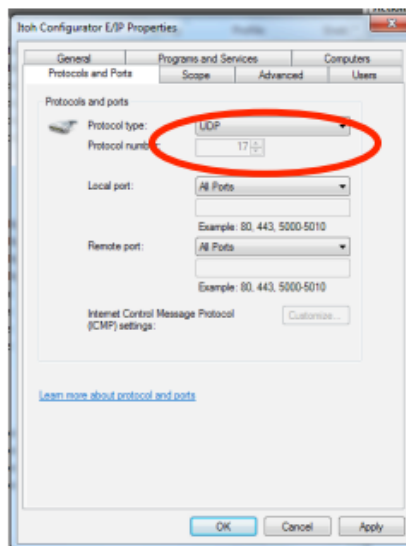

Windows Firewall has been manually configured.

4. ITOH CONFIGURATOR E/IP

- If the Windows Firewall setting was configured, but both “Public” and “Private” network selections were not checked when the alert was displayed, the settings can be changed.

- 14. Click on the “Advanced” tab

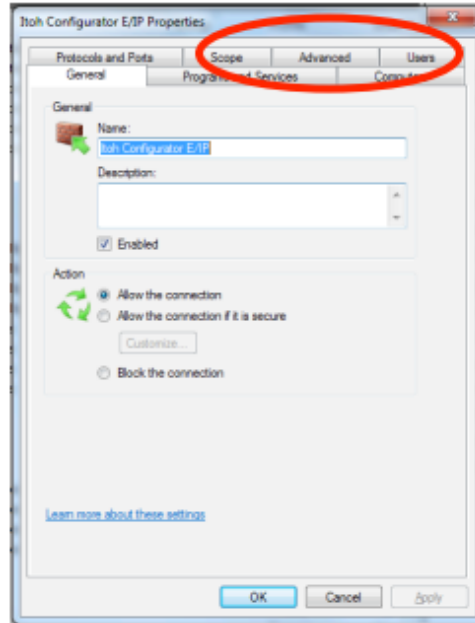

- 15. Select both “Private” and “Public” under “Profiles”, and then click “OK”

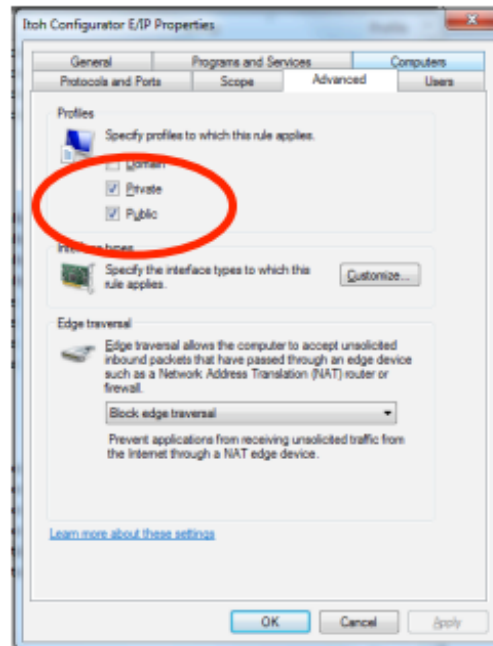

- 16. Repeat steps 14 and 15 for the other “Itoh Configurator E/IP” rule

MAIN WINDOW:

- The Main Window is the graphical user interface for the Itoh Configurator E/IP software. This window provides access to different aspects of the project IB-E modules such as configuration, programming, and diagnostics.
- The title bar for the Main Window displays the name of the software along with its version. The name of the logic opened in the Program Display will appear between the brackets in the title bar.



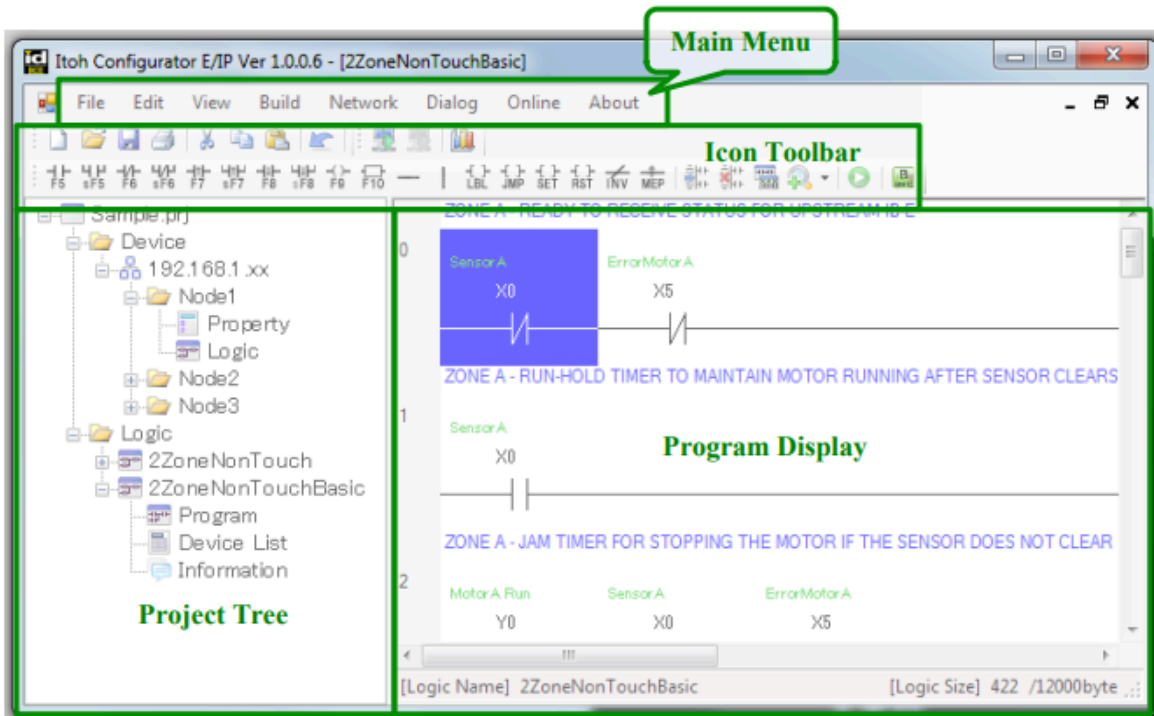































- There are four areas of the main window with which to be familiar:
 - Main Menu
 - Icon Toolbar
 - Project Tree
 - Program Display



MAIN MENU:

Menu	Sub-Menu	Description
File	New Project	Create a new project
	Open	Open an existing project
	Close	Close current project
	Save	Save current project
	Save As	Save current project with a different name
	Print Setup	Set up printer
	Print Preview	Print preview
	Print	Print
	Exit	Close Itoh Configurator E/IP
Edit	Undo	Undoes most recent change
	Cut	Cut selected area
	Copy	Copy selected area
	Paste	Paste
	Delete	Delete Selected area
	Find/Replace	Opens the Find and Replace window
View	Comment	Shows or hides rung element comments
	Line Comment	Shows or hides line comments
	Zoom	Zoom (50%, 75%, 100%, 125%)
Build	-	Build (compile)
Network	Reset	Sends a reset signal to the IB-E modules
	Run	Starts ladder logic
	Stop	Stops ladder logic
Dialog	Discovery	Shows connected IB-E modules and allows a batch change for the network settings
	Information	Displays ladder logic information, connection status, lifetime data, serial number, firmware version, and MAC address
	Jog Control	Forces motor operation and remote output condition
	Error Information	Displays error information and resets any errors
	Auto Download	Automatic download for device replacement
	Mechanical Test	Experimental mounting failure test
Online	Start	Start ladder logic monitor
	Stop	Stop ladder logic monitor
About	Firmware Update	Upgrade IB-E firmware
	About Itoh Configurator E/IP	Displays Itoh Configurator E/IP version

ICON TOOLBAR

Icon	Description	Shortcut Keys
	Create new project	Ctrl + N
	Open existing project	Ctrl + O
	Save project	Ctrl + S
	Print program display	Ctrl + P
	Cut selected area	Ctrl + X
	Copy selected area	Ctrl + C
	Paste	Ctrl + V
	Undo	Ctrl + Z
	Start ladder logic monitor	-
	Stop ladder logic monitor	-
	Normally open contact	F5
	Parallel connection of normally open contact	Shift + F5
	Normally closed contact	F6
	Parallel connection of normally closed contact	Shift + F6
	Rising-edge pulse contact	F7
	Parallel connection of rising-edge pulse contact	Shift + F7
	Falling-edge pulse contact	F8
	Parallel connection of falling-edge pulse contact	Shift + F8
	Normally open coil (output)	F9
	Function Block	F10
	Horizontal line	Ctrl + Cursor key
	Vertical line	Ctrl + Cursor key
	Label	-
	Jump	-
	Set (latch) coil	-
	Reset (unlatch) coil	-
	Invert operation result	-
	Convert operation result to leading edge pulse	-
	Add line	Shift + Insert
	Delete line	Shift + Delete
	View or hide comment(s)	-
	Zoom (in/out)	Ctrl + scroll wheel
	Build (compile)	F4
	Basic or Advanced programming modes	F12

5. WORKING WITHIN THE ENVIRONMENT

PROJECT TREE:

- The Project Tree displays the project name and an expanding tree of devices (registered IB-E modules) and logics (programs used in the projects).
- The Device tree provides access to the property/configuration window.
- The Logic tree allows the user to select which program is visible in the Program Display.

PROGRAM DISPLAY:

- The Program Display is a window that shows the ladder logic selected from the Project Tree. It also is the window that allows the user to create and edit the logic.
- The title bar of the main window indicates which logic is shown in the Program Display.
- Refer to Chapter 7 for more information on using the ladder diagram editor.

CREATING A NEW PROJECT:

- A new project can be created by either:
 - Clicking on “File” in the main menu, then selecting “New Project” from the list
 - OR clicking on the “New Project” icon in the icon toolbar

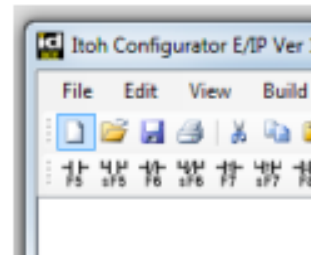
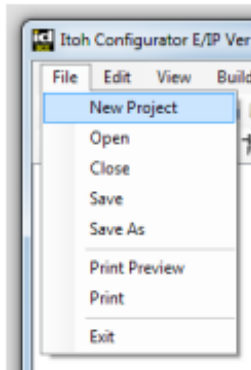

- Next, enter the name of the new project, and then click “OK”

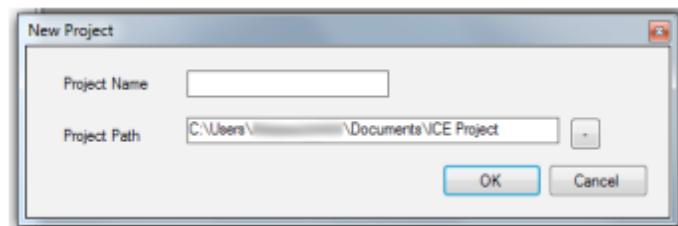

- The Project Tree will be populated with the project name

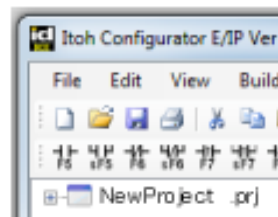

- Expand the project by clicking on the “+” icon

5. WORKING WITHIN THE ENVIRONMENT

PROJECT TREE:

- The project tree provides access to node and logic properties for the project

ADDING A NODE:

- Add a new network and node to the project
- Select “Device”
- Right-click on it and select “Add”
- Change the subnet to match the IB-E module’s default IP subnet, 192.168.1.xx (or another subnet)
- Note: This does not change the IB-E modules IP address.
- Assign a new node ID, and then click “OK”

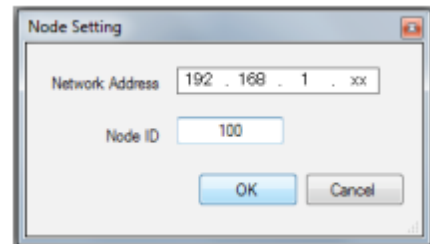
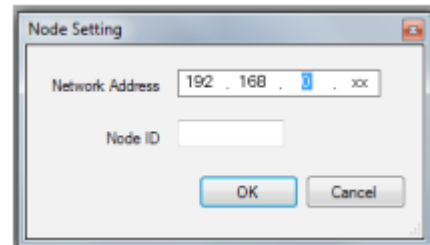
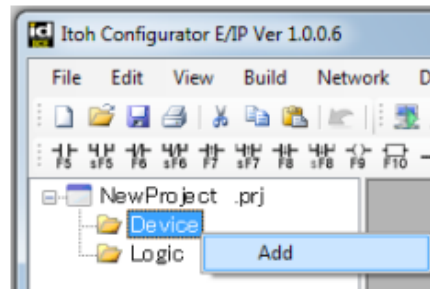

DELETING A NODE:

- An existing node can be deleted, removing it from the IP address subnet tree.
- Select the node to be deleted
- Right-click on the node and select “Delete”
- Confirm the prompt to delete the node
- The node is removed from the IP address subnet tree

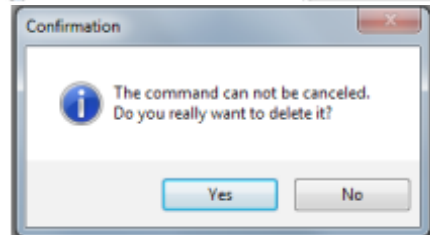
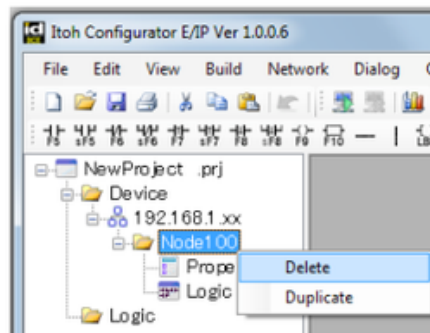

5. WORKING WITHIN THE ENVIRONMENT

DUPLICATING A NODE:

- An existing node can be duplicated, copying all parameters to a new node
- Select the node to be duplicated
- Right-click on the node and select “Duplicate”
- Assign a new node ID (subnet cannot be changed), and then click “OK”
- The new node will be shown under the IP address subnet tree

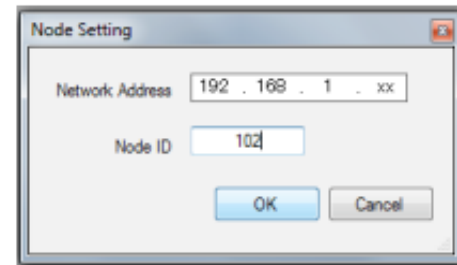
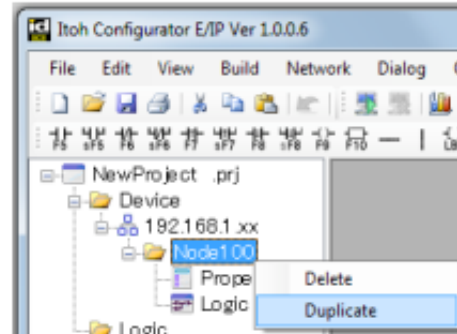

ADDING A LOGIC:

- Add a new logic to the project
- Select “Logic”
- Right-click on it and select “Add”
- Enter the name for the logic and the name of the writer (if desired), and then click “OK”
- Note: Spaces and other special characters are not permitted for the logic’s “Name”. However, letters, numbers, underscores, and hyphens, are acceptable.
- The new logic will be shown under the logic tree

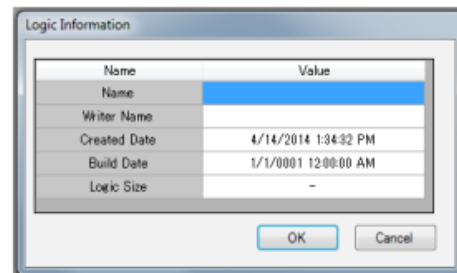
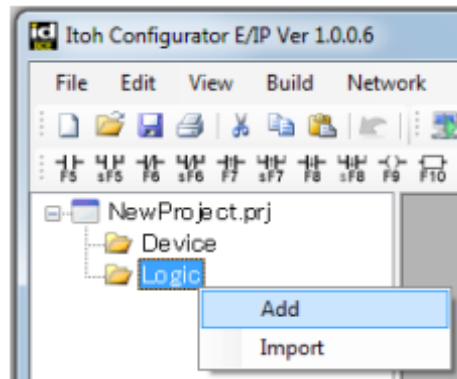

5. WORKING WITHIN THE ENVIRONMENT

DELETING A LOGIC:

- An existing logic can be deleted, removing it from the logic tree
- Select the logic to be deleted
- Right-click on the logic and select “Delete”
- Confirm the prompt to delete the logic
- The logic is removed from the logic tree

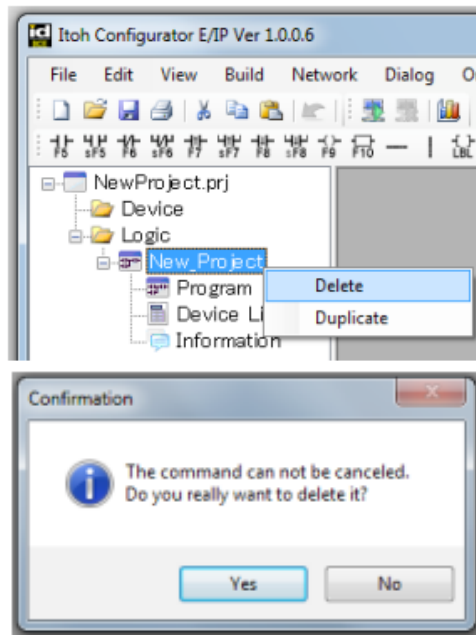

DUPLICATING A LOGIC:

- An existing logic can be duplicated, copying all functions to a new logic
- Select the logic to be duplicated
- Right-click on the logic and select “Duplicate”
- Enter a new name for the duplicated logic and the name of the writer (if desired), and then click “OK”
- Note: Standard operating system file name rules apply to the logic’s name. Spaces and other special characters are not permitted for the logic’s name. However, letters, numbers, underscores, and hyphens, are acceptable.
- The duplicated logic will be shown under the logic tree

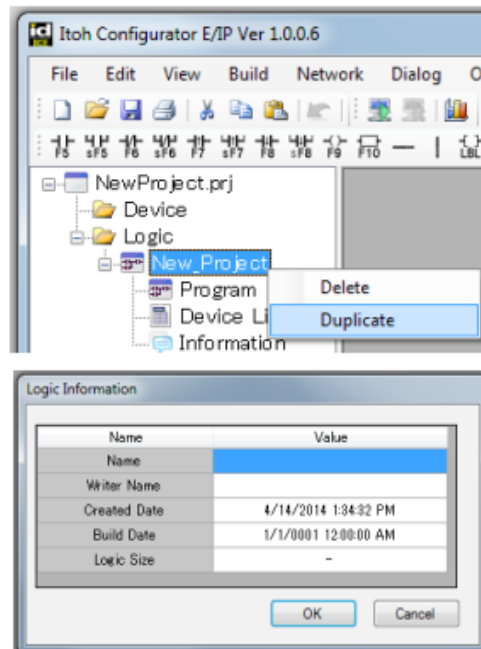

5. WORKING WITHIN THE ENVIRONMENT

OPENING LOGIC:

- A quick way to view a Node's logic (ladder diagram), which has been assigned under the Node's properties, is to double-click on "Logic" under that node.
- The ladder diagram for the assigned logic will be shown in the Program Display.
- Another option is to double-click on "Program" under the logic's name
- Refer to Chapter 5 for more information about programming

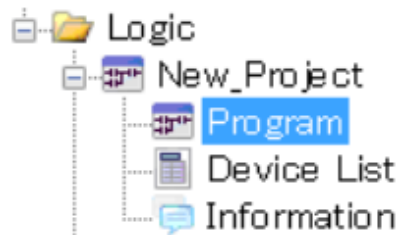
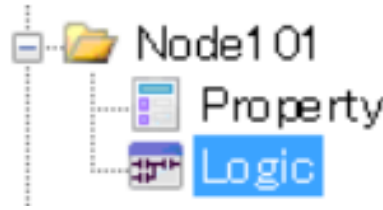

DEVICE LIST:

- The Device List allows the user to see all the logic elements available, if they are used (*) in the logic, and what state they are in when monitored.

Device Type X					
	Address	Comment	Value	↑↓	←→
▶	0	SensorA	-	*	
	1	SensorB	-	*	
	2	RemoteIN1	-		
	3	RemoteIN2	-		
	4	RemoteIN3	-		

- The Device Type drop-down list selects different ranges of logic elements
 - X – Predefined Boolean input elements (sensors, auxiliary inputs, etc.)
 - Y – Predefined Boolean output elements (motor run, direction change, etc.)
 - M – User-defined Boolean internal elements
 - D – Data registers, 1Byte each
 - T – Timers
 - C – Counters
 - PC – Pulse counters
 - S – Special purpose elements
 - SD – Self data register, only used for Node ID
- Refer to Chapter 5 for more information on how to use these elements in the program

5. WORKING WITHIN THE ENVIRONMENT

NETWORK:

■ The “Network” window allows the user to send Reset, Run, and Stop messages to the IB-E modules on the network. The messages can be sent to one node, which is selected from a dropdown list. Or, the message can be broadcast to all nodes.

- Reset – Restarts the internal logic. It is the same state as powering the IB-E module on.
- Run – Resumes logic operations. This is only necessary if the logic was stopped.
- Stop – Stops logic operations.

■ Example of Reset for all nodes

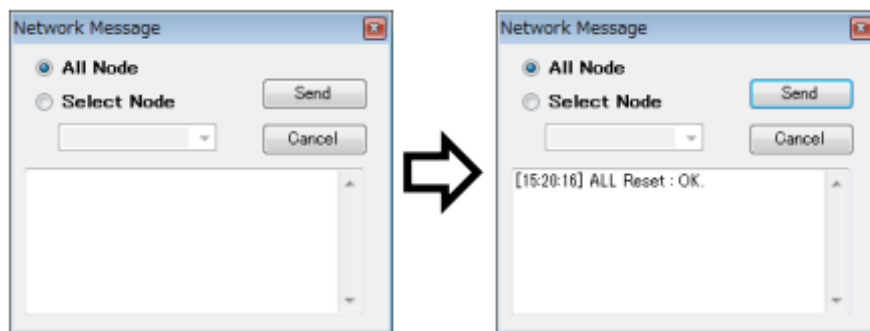

DISCOVERY:

■ The “Discovery” window allows the user to change the IB-E module’s network settings, as well as identifying the IB-E modules connected to the network.

■ Open the Discovery from Main Menu – Dialog

■ Note: In order to properly use “Discovery”, the PC’s IP address must be on the same subnet as the connected IB-E modules. The factory default IP address subnet is 192.168.1.xxx.

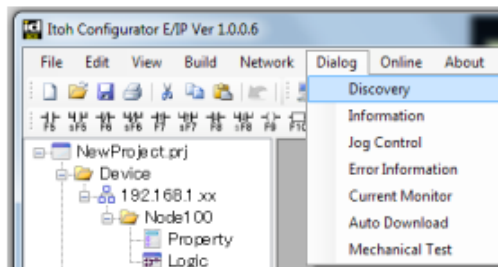

5. WORKING WITHIN THE ENVIRONMENT

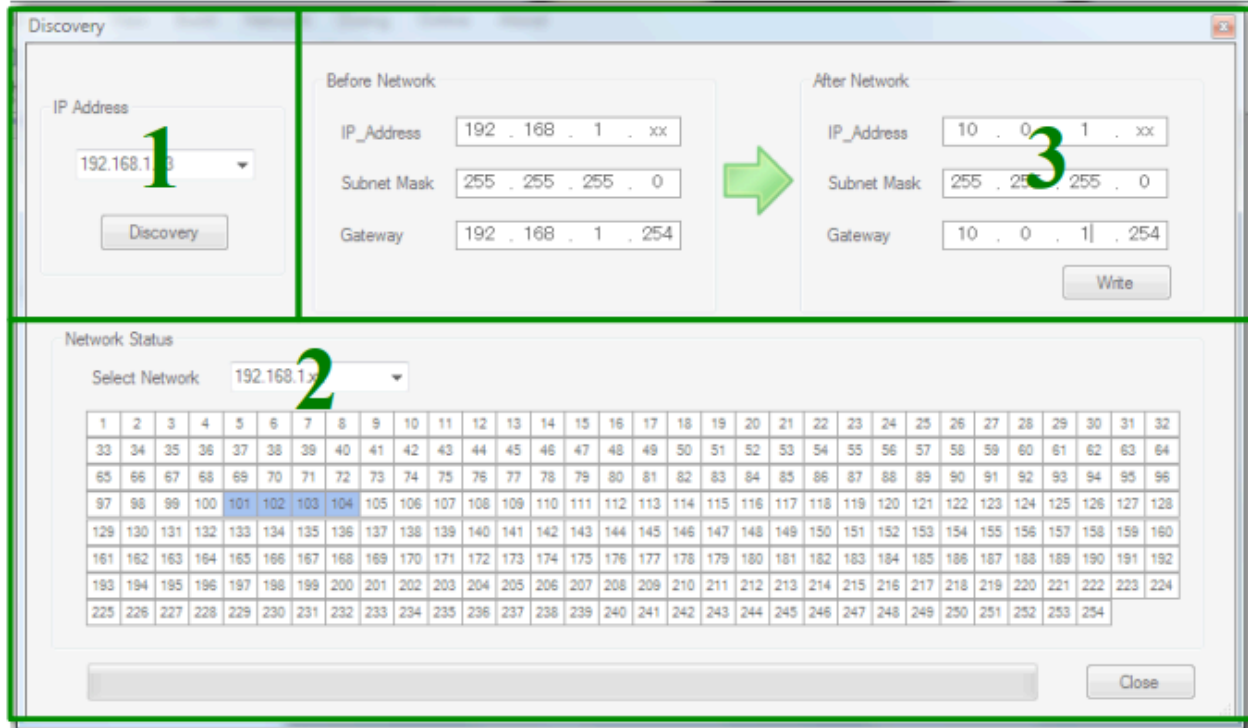

CONNECTED MODULES:

- To see all the modules connected to the (particular subnet) network:
 1. Inside the “IP Address” section, select the PC’s IP address from the dropdown list, and then click on “Discovery”
 2. Inside the “Network Status” section, select the IB-E (subnet) network from the dropdown list
- The node IDs (last octet of the IP address) of the connected IB-E modules will be shown in blue.

CHANGE IP ADDRESS:

- To change the IP address subnet of the IB-E modules
- Follow steps 1 & 2 from the above section (Connected Modules)
 3. Inside the “After Network” section, fill in the appropriate network information, and then click on “Write”
- Note: “Before Network” displays the current network settings. “After Network” displays what the network settings will be *after* “Write” is clicked.

INFORMATION:

- The “Information window” displays information on the nodes listed in the project, such as connection status, logic, motor life, serial number, firmware versions, and MAC ID for each IB-E.

- Open the Information from Main Menu – Dialog

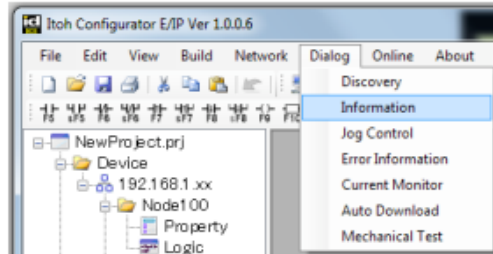

Status	Node Address	Logic Name	Build Date	Life Time(A)	Life Time(B)	Serial No	Firm Ver(1)	Firm Ver(2)	Firm Ver(3)	MAC
Disconnected	192.168.1.100	-	-	-	-	FFFFFFFF	010A	013D	1010	00-22-21-00-20-ED
Connected	192.168.1.101	-	-	000%	000%	FFFFFFFF	010A	013D	1010	00-22-21-00-20-ED

- If the node is not listed in the project, then it will not appear in the information window.
- If a node is listed in the project, but it is not connected on the network, then the node will be shown as “Disconnected”.
- Lifetime is an estimation of motor usage represented in hours and displayed as a percentage of “used” hours of life. It is determined by an algorithm based on factors such as current draw, roller speed vs. set speed, start/stops, run time, temperature, etc. The hours accumulate more rapidly as the load to the motor increases.

JOG CONTROL:

- The “Jog Control” window controls the motors and outputs independently of the logic. In this manner, the motor drive and auxiliary output circuits can be diagnosed separate from any logic issues.

- Open the Jog Control from Main Menu – Dialog

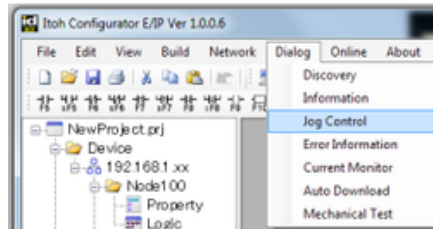

- Select the IP address of the IB-E module to jog, and then click “Enable”

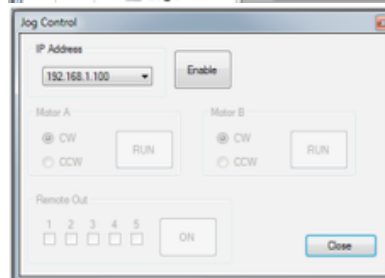

- Select motor direction, Clockwise (CW) or counter-clockwise (CCW), and then click “RUN”
- Select remote outputs, and then click “ON”
- Click “Disable” to turn off Jog Control

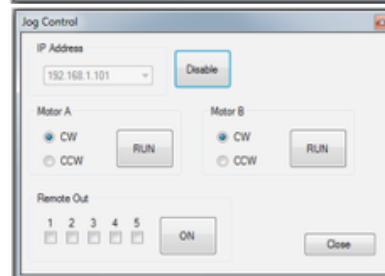

5. WORKING WITHIN THE ENVIRONMENT

CURRENT MONITOR:

- The “Current Monitor” window displays a “live” reading of the current draw for each motor drive circuit.

- Open the Current Monitor from Main Menu – Dialog

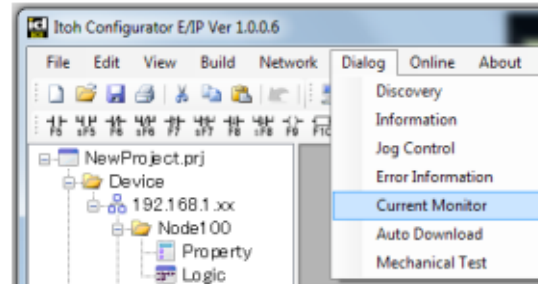

- Select the PC’s IP address

- Note: In order to properly use “Current Monitor”, the PC’s IP address must be on the same subnet as the connected IB-E modules. The factory default IP address subnet is 192.168.1.xxx.

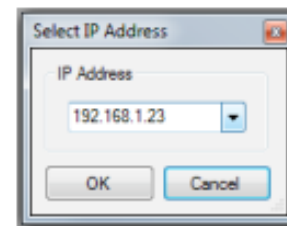

- Select the style of display
- Select the window’s refresh time
- Select which motor (A, B or both) is displayed in the window. Motor A is **red**, and Motor B is **green**.
- Select which current limit (range) is displayed
- Select which IB-E (IP address) is monitored
- Click “Start” to begin current monitoring and “Stop” to end it

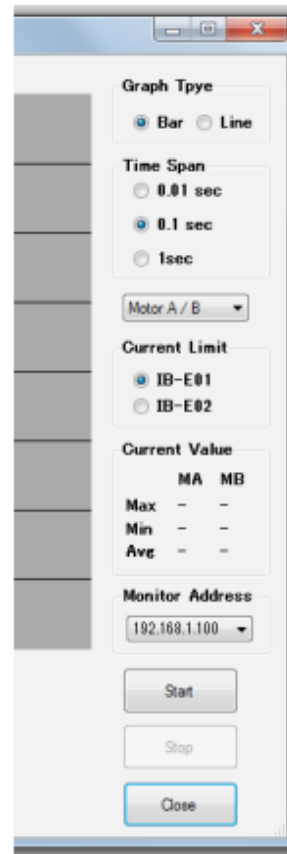

5. WORKING WITHIN THE ENVIRONMENT

AUTO DOWNLOAD:

- The “Auto Download” window sets up and activates the automatic device replacement feature. This allows each IB-E to hold the configuration and logic for two other IB-E modules, one immediately higher (+1) and one immediately lower (-1) in the IP address numerical sequence.
- For example, IP address 192.168.1.33 would hold the configuration and logic information for both 192.168.1.32 (33-1) and 192.168.1.34 (33+1).
- The first (or lowest) IB-E module in the IP address sequence will only hold for one immediately higher (+1) IP address. The last (or highest) IB-E module in the IP address sequence will only hold for one immediately lower (-1) IP address.
- Note: In order for this feature to work, the replacement IB-E module must have the same IP address subnet as the adjacent modules. If the network’s IP address subnet is not the default 192.168.1.xxx, then the replacement IB-E must first have its IP address subnet changed using ICE.

- Open the Auto Download from Main Menu – Dialog

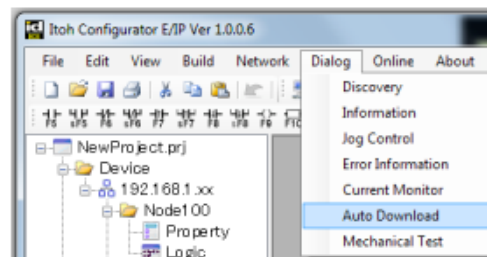

- Select which IB-E modules (IP addresses) will utilize this feature, and then click “Write”

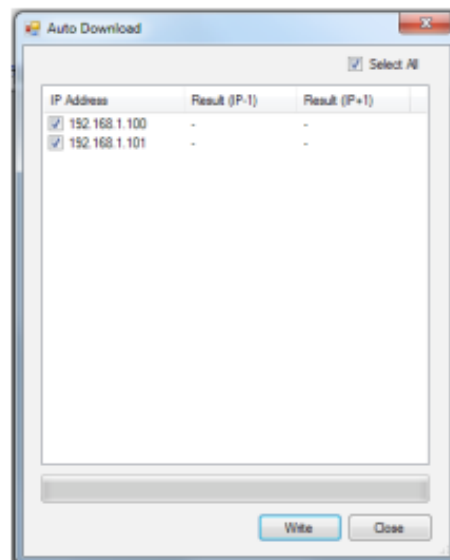

5. WORKING WITHIN THE ENVIRONMENT

MECHANICAL TEST:

- The “Mechanical Test” window is an experimental feature to determine the likelihood of a motorized roller mounting bracket failure.

- Open the Mechanical Test from Main Menu – Dialog

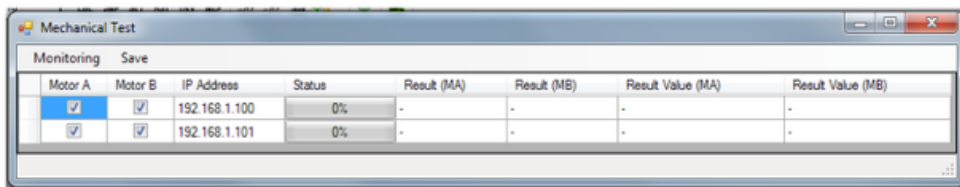
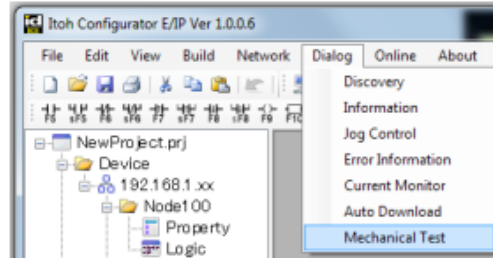

- This test is performed without a load to the motorized roller

FIRMWARE UPDATE:

- The “Firmware Update” window allows the user to update the IB-E firmware, if one is available. There are two separate processors, one for the communication and logic control and another for the motor drive control.

- Open the Firmware Update from Main Menu – About

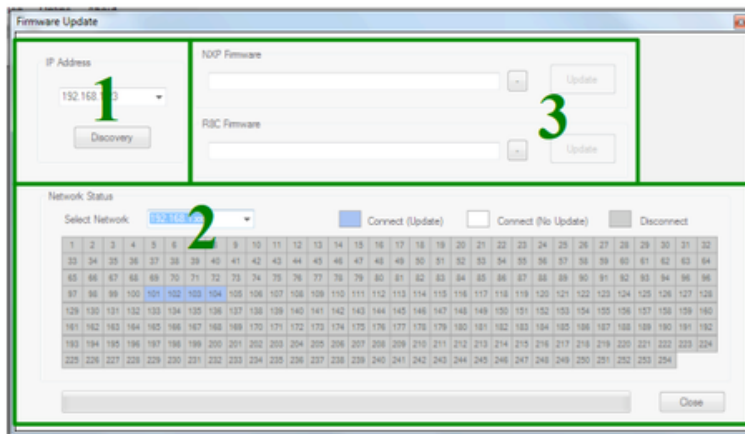

1. Inside the “IP Address” section, select the PC’s IP address from the dropdown list, and then click on “Discovery”
2. Inside the “Network Status” section, select the IB-E (subnet) network from the dropdown list
The node IDs (last octet of the IP address) of the connected IB-E modules will be shown in blue.
3. Click on the “-” button to browse to the firmware file, and then click “Update”

6. CONFIGURING IB-E

PROPERTY SETTING:

- The Property Setting window accesses configuration parameters for the IB-E modules.

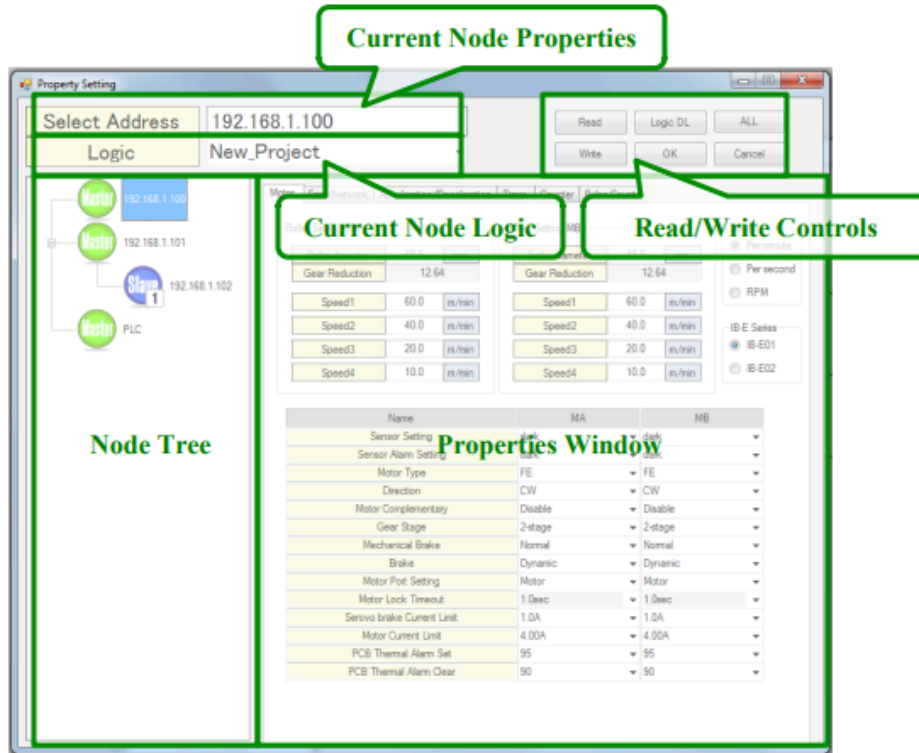

CURRENT NODE PROPERTIES:

- This field displays the IP address of the node whose parameters are shown in the Properties window. To change the properties of another node, double-click an IP address shown in the Node Tree.

CURRENT NODE LOGIC:

- This field displays the logic that is assigned to the node shown in the current node field. This is a drop-down list populated by all the logics that are created in the Project Tree. To change the logic, open the drop-down list and select another one. Click on "Logic DL" to download the new logic to the IB-E. The logic must be built/compiled before being downloaded.

READ/WRITE CONTROLS:

- These buttons allow the user to read and write configuration parameters to-and-from the IB-E, as well as downloading logic. The PC's IP address must be on the same subnet as the modules.

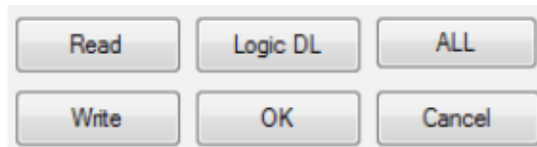

6. CONFIGURING IB-E

- **Read:** reads all properties from the *current* node IB-E and updates the properties window

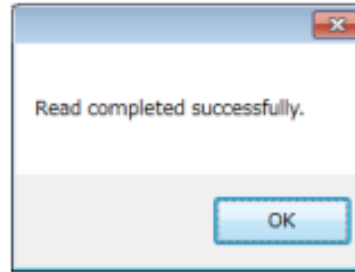

- A prompt will indicate whether the read was successful or not

- **Write:** Writes all properties from the properties window into the *current* node IB-E

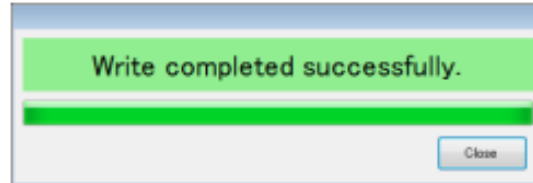

- A progress bar and prompt will indicate whether the write was successful or not

- **Logic DL – Downloads the logic listed in the “current node logic” field into the IB-E node with the IP address shown in the “Select Address” field. The logic must be built/compiled before downloading.**

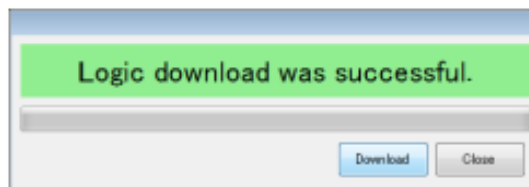

- A progress bar and prompt will indicate whether the write was successful or not

- **OK – Maintains the present property fields, and then closes the Property Setting window**

- **ALL – Opens a new window to upload properties from all the connected IB-E modules, or to download all the properties and logic to the connected IB-E modules**

- It is possible to read/write properties to all or specified (checked) IB-E modules, as well as writing (downloading) logic to all or specified (checked) IB-E modules. Properties and logic can be handled separately.

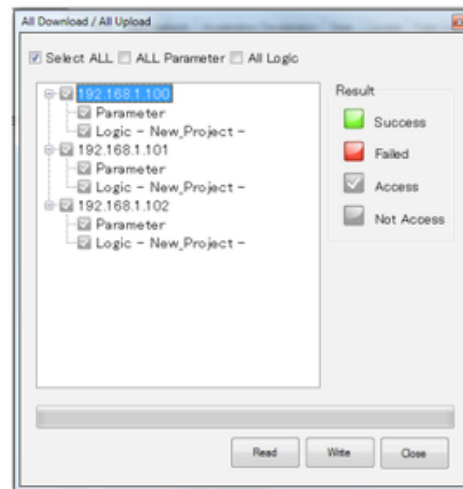

- A prompt will indicate whether the write was successful or not

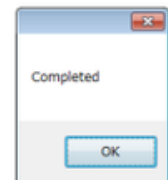

- **Note:** After the writes (downloads) have completed, the IB-E modules will reset

- **Cancel – Discards any changes since the last opening of the Property Setting window, and then closes the Property Setting window**

PROPERTIES WINDOW:

- The Properties Window provides access to all of the configurable settings available in the IB-E and its logic. It is organized into different tabs. For more information, see the sections for each tab.

NODE TREE:

- The Node Tree provides allows the user to switch between IB-E nodes in order to change their properties. To switch to another IB-E, double click on the IP address of the desired node. Also, by clicking on an IP address, then right-clicking it, an IB-E can be configured as a master or a slave (refer to Chapter 6 – Master/Slave).

MOTOR TAB:

- The Motor Tab allows access to motor driver properties on the IB-E.

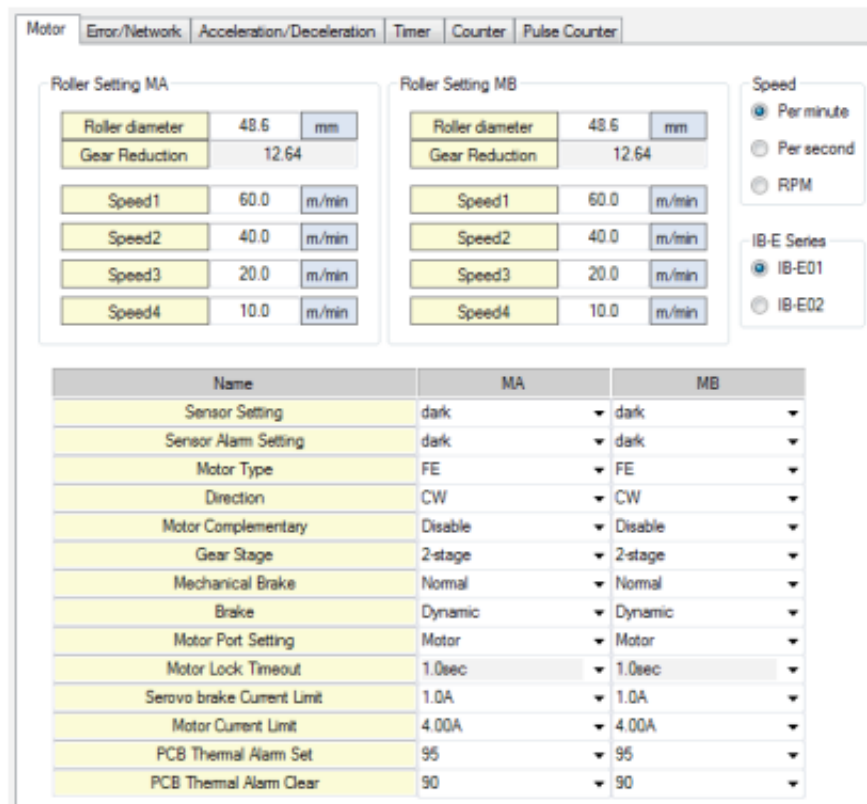

Motor Error/Network Acceleration/Deceleration Timer Counter Pulse Counter

Roller Setting MA

Roller diameter	48.6	mm
Gear Reduction	12.64	
Speed1	60.0	m/min
Speed2	40.0	m/min
Speed3	20.0	m/min
Speed4	10.0	m/min

Roller Setting MB

Roller diameter	48.6	mm
Gear Reduction	12.64	
Speed1	60.0	m/min
Speed2	40.0	m/min
Speed3	20.0	m/min
Speed4	10.0	m/min

Speed

Per minute
 Per second
 RPM

IB-E Series

IB-E01
 IB-E02

Name	MA	MB
Sensor Setting	dark	dark
Sensor Alarm Setting	dark	dark
Motor Type	FE	FE
Direction	CW	CW
Motor Complementary	Disable	Disable
Gear Stage	2-stage	2-stage
Mechanical Brake	Normal	Normal
Brake	Dynamic	Dynamic
Motor Port Setting	Motor	Motor
Motor Lock Timeout	1.0sec	1.0sec
Servo brake Current Limit	1.0A	1.0A
Motor Current Limit	4.00A	4.00A
PCB Thermal Alarm Set	95	95
PCB Thermal Alarm Clear	90	90

ROLLER DIAMETER:

- The Roller Diameter field is a user-defined input. This diameter is in reference to the overall diameter of the motorized roller *including* any coating (rubber lagging) or cover (urethane sleeve). The unit for this field is millimeters (mm).

6. CONFIGURING IB-E

GEAR REDUCTION:

- The Gear Reduction is the calculated value of motor revolutions per tube revolution. The Gear Stage setting and the Motor Type setting determine the gear reduction.
- Note: This field is not selectable unless the Motor Type is set to “Other”.

ROLLER SPEED:

- The Roller Speed fields are user-defined inputs. The roller speed is in reference to the linear, or surface speed, of the motorized roller including any coating or cover. The units for these fields are set by the Speed units selection.
- There are four (4) presets. By using the appropriate output bits, the motorized roller can be changed to one of these preset speeds while in operation.
 - Speed 1 – This field sets the default speed. If no preset speed is selected by the logic, then this is the speed the motorized roller operates. This should always be set as the fastest speed.
 - Speed 2 – This field sets a second speed preset. Speed 2 should be less than Speed 1.
 - Speed 3 – This field sets a third speed preset. Speed 3 should be less than Speed 2.
 - Speed 4 – This field sets a fourth speed preset. Speed 4 should be less than Speed 3.
- Note: Speed preset priority in logic, when multiple speed outputs are simultaneously used: Speed1 > Speed2 > Speed3 > Speed4

ROLLER SPEED:

- The Speed units selection determines which unit and time bases are used.
 - m/min – Meters per minute
 - m/sec – Meters per second
 - RPM – (Motor) Revolutions per minute (display only)
 - The RPM is the calculated value of motor revolutions per minute. The Gear Reduction, Speed units, Roller Diameter, and Roller Speed settings determine it.
 - Motors have physical speed limits. Therefore, a motor’s fastest physical RPM may be slower than the set RPM.
- Note: Regardless of the motorized roller, the operating range of the brushless DC driver is 621 to 6000 RPM. If any Roller Speed setting is out of the driver’s operating range, a warning will be indicated.

IB-E SERIES:

- Selects which model IB-E is being configured
 - IB-E03A – 4A current limit, 10-pin motor connector, applicable for FE, FP, and FS family Power Mollers
 - IB-E04F – 7A current limit, 12-pin motor connector, applicable for FH and KT (KE) family Power Mollers.

6. CONFIGURING IB-E

SENSOR SETTING:

- The Sensor Operation selection determines the way the sensor status bit responds to the sensor input signal. The naming is based on the output signal of photoelectric sensors, either being dark or light operate.
 - Dark – This is the default setting in which the sensor status bit is “1” when the input is ON, and “0” when the input is OFF.
 - Light – This setting reverses the sensor status bit, so that it is “1” when the input is OFF, and “0” when the input is ON.

SENSOR ALARM SETTING:

- The Sensor Alarm Operation selection determines the way the sensor alarm status bit responds to the sensor alarm input signal. For the sensors, which use it, the sensor alarm is a status bit to indicate the “health” of a sensor.
 - Dark – This is the default setting in which the sensor alarm status bit is “1” when the input is ON, and “0” when the input is OFF.
 - Light – This setting reverses the sensor alarm status bit, so that it is “1” when the input is OFF, and “0” when the input is ON

MOTOR TYPE:

- The Motor Type selection determines the model of motor/roller connected to the IB-E. It affects baseline gear reduction and motor direction parameters.
 - NA – This setting is only for when the motor port is not being used.
 - FE – Default setting, “standard” torque motor. If the motorized roller is a PM635FS (2.5” diameter), use this setting.
 - FS – This setting is for different “standard” torque motor. Due its design, it has a slightly lower gear reduction and rotates in the opposite direction of an “FE”.
 - FP – This setting is for a “high” torque motor. It has the same gear reduction and rotation as the “FS”.
 - FH – This setting is only available within the IB-E04 (IB series) selection. It is for a high power motor.
 - KE – This setting is only available within the IB-E04 (IB series) selection. It is for a larger, more powerful motor.
 - Other – This setting for other motor/gear ratio combinations

Diameter (in)	Model	Setting
1.91	PM486FE	FE
	PM486FP	FP
	PM486FS	FS
	PM486FH	FH
1.97	PM500FE	FE
	PM500FP	FP
	PM500FS	FS
	PM500FH	FH
2.24	PM570FE	FE
	PM570KT	KE
2.38	PM605FE	FE
	PM605KT	KE
2.50	PM635FS	FE
	PM635KT	KE

6. CONFIGURING IB-E

DIRECTION:

- The Roller Direction sets the default turning direction of the motorized roller. The direction is always referenced from the cable-side of the motorized roller. It is also dependent upon the Motor Type parameter.
 - CW: Clockwise
 - CCW: Counter Clockwise

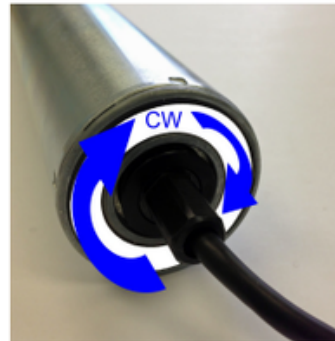

MOTOR COMPLEMENTARY:

- The Motor Complementary selection determines the way the driver circuit maintains the set speed.
 - Disable – This is the default setting which allows the full range of RPM for a given motor and maintains the set speed by increasing power (within the usable power range) to the motor as the load increases. The increase in power is inversely proportional to the motor’s set RPM. The slower the motor’s RPM is set, the more power will be available to maintain the set speed. However, the usable power range is affected by the Current Limit setting.
 - Enable – This setting operates the motor in a lower range of RPM. It is designed to maintain the set speed whether the roller is moving faster or slower. Due to power limitations, the ability to slow down is much less than that of speeding up. If slowing the speed requires too much power, the motor will shut off and use the dynamic brake to stop.

GEAR STAGE:

- The Gear Stage selection determines the gear reduction based on the number of planetary gear stages within the motorized roller’s gearbox. The model’s speed code determines the number of stages present within the roller.

Speed Codes for PM486FE/FS/FP/FH	Gear Stages
5 8 10 15 17	3
20 30 45 55 60	2
70 100 140 190 210 255	1

- Example: PM486FE-60 (“60” is the speed code) has 2 gear stages.

Speed Codes for PM635FS	Gear Stages
6 10 15 20	3
25 40 60 75	2

- Example: PM635FS-6 (“6” is the speed code) has 3 gear stages.
- Note: When using a PM635FS motorized roller, use the “FE” motor type for proper speed and direction settings.

Speed Codes for PM635KT	Gear Stages
16	3
60	2
230	1

- Example: PM635KT-16 (“16” is the speed code) has 3 gear stages.
- Note: When using a PM635KT motorized roller, use the “KE” motor type for proper speed and direction settings.

6. CONFIGURING IB-E

MECHANICAL BRAKE:

- The Mechanical Brake selection determines if the mechanical brake (an option for the motorized roller) operates normally or is disengaged even when the motor is not running. By disengaging the mechanical brake, the motorized roller with the mechanical brake option operates as a standard motorized roller without the brake. This only applies while the IB-E is powered.
 - Normal – Default setting in which the mechanical brake is engaged while the motor is OFF.
 - Disengaged – This setting keeps the mechanical brake disengaged while the motor is OFF.

BRAKE (ELECTRIC):

- The (electric) Brake mode selection determines the way in which the motor behaves when it is not driven.
 - Dynamic – Default setting in which the power generated by the motor is consumed in order to stop the motor quickly. The effect of the dynamic brake is proportional to the speed of the motor. The faster the motor is spinning, the stronger the braking force of the dynamic brake.
 - Coast – This setting allows the motor to freely spin. The only resistance to the motorized roller is mechanical. If a motorized roller with a mechanical brake is used with this setting, the mechanical brake will be disengaged.
 - Servo – This setting activates a dynamic brake for 0.2s, and then monitors the motor's position. Depending on conditions, the servo brake mode will resist turning and/or nearly return to the original position from which the motor's position was initially being monitored. If a motorized roller with a mechanical brake is used with this setting, the mechanical brake will be disengaged.

MOTOR PORT SETTING:

- The Motor Port Setting determines the mode of operation for the driver circuit.
 - Motor – This is the default setting that is used to drive the brushless DC motorized roller.
 - Port(Nch) – This setting is not used to drive a motor. Rather, each motor driver phase functions as a discrete output providing an additional three (3) outputs per motor driver. The outputs are NPN (sinking) only. This setting also disables the Motor Disconnected Error status.
- Note: Refer to the section on “Configuration” for more information on wiring precautions when using the motor port discrete output function

MOTOR LOCK TIMEOUT:

- The time until an error is indicated when the motor is being driven, but the motorized roller cannot turn (stalled).

SERVO BRAKE CURRENT LIMIT:

- The Servo Brake Current Limit selection adjusts the amount of current the motorized roller will draw when in servo brake mode. It can be adjusted in 0.1A increments from 0.1 to 1.0A.

MOTOR CURRENT LIMIT:

- The Current Limit selection adjusts the maximum current that can be drawn by the motorized roller. Current draw may be reduced to lower overall power consumption. However, this will also reduce motor performance. It can be adjusted in 0.25A increments from 0.50 to 4.00A.

6. CONFIGURING IB-E

CIRCUIT BOARD THERMAL PROTECTION:

- The Circuit Board Thermal Protection selection adjusts the thermal triggers for the brushless DC motor driver.
 - PCB Thermal Alarm Set – When the motor driver reaches this temperature, the motor will stop and an error status will be reported.
 - PCB Thermal Alarm Clear – The error status is cleared when the driver cools to this temperature. The Alarm Clear temperature must be less than the Alarm Set temperature.

ERROR/NETWORK TAB:

- The Error/Network tab allows access to error status handling and network communication configuration.

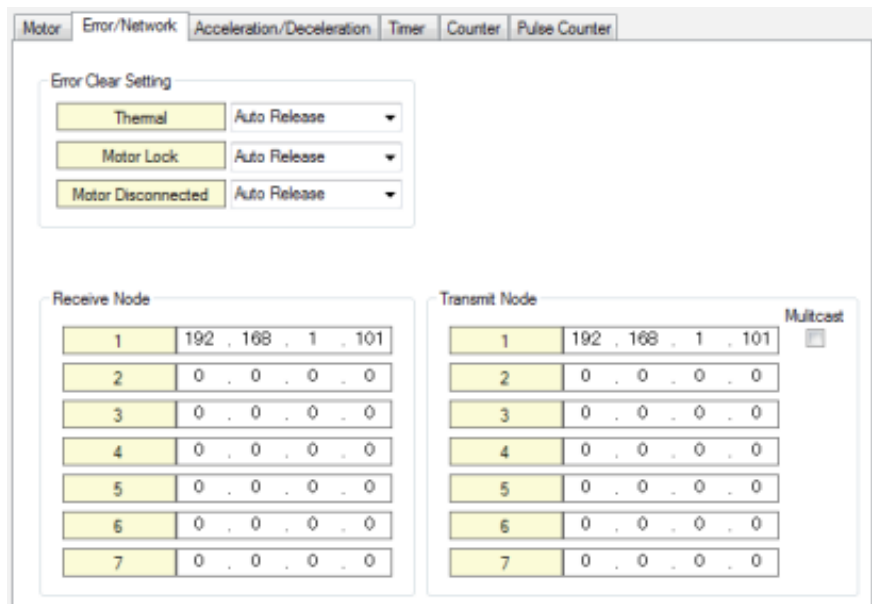

THERMAL:

- The Thermal error status activates when the motor or the driver circuit reaches thermal limit (triggered by thermistors).
 - Auto Release – The error resets automatically when the motor or the driver cools to the operating temperature range.
 - Host Release – After the motor or the driver cools to the operating temperature range, the error can reset by ICE or an EtherNet/IP implicit message.

MOTOR LOCK:

- The Motor Lock error activates when the motor is being driven, but the motorized roller cannot turn (stalled).
 - Auto Release – The error resets automatically when the motor is turned by hand (manually).
 - Host Release – The error can be reset by ICE or an EtherNet/IP implicit message.

6. CONFIGURING IB-E

MOTOR DISCONNECTED:

- The Motor Disconnected Error status activates when the motor is not plugged into the motor port AND the Motor Port Function parameter (Driver Configuration tab) is set to Motor Driver.
 - Auto Release – The error resets automatically when the motor has been plugged into the motor port.
 - Host Release – After the motor has been plugged into the motor port, the error can be reset by ICE or an EtherNet/IP implicit message.

RECEIVE AND TRANSMIT NODES:

- This area defines the nodes (IP addresses), which will communicate with the current node
- The following image shows node 101 (last octet) communicating with nodes 100, 103, and 104. For most situations, the IP addresses and their order will be the same for both Receive and Transmit.

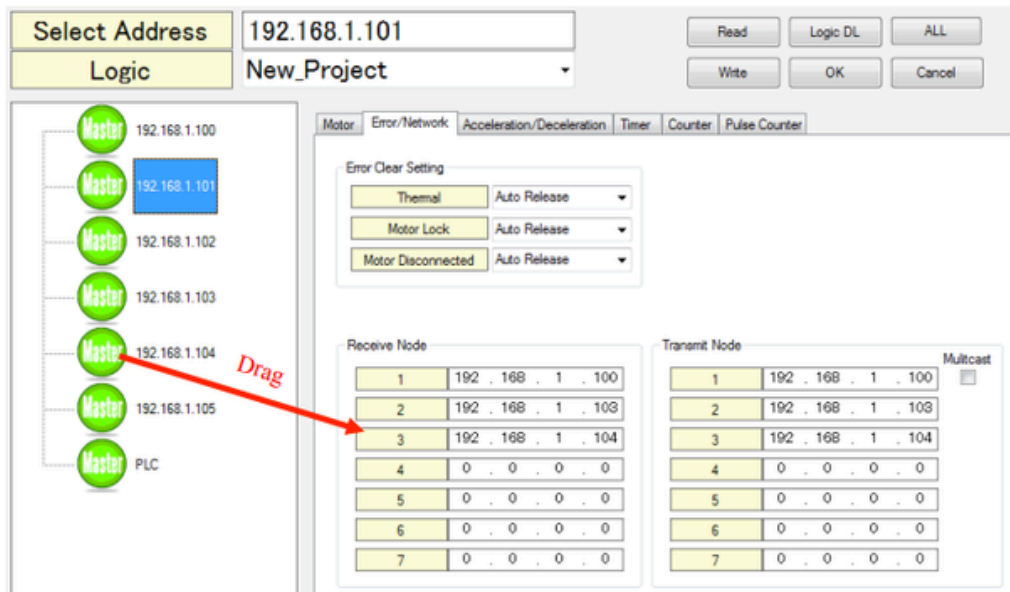

- The connection number (1-7) indicates which range of predefined internal registers is used for the target IP address. This is important to keep in mind, because there are logic inputs and outputs that are associated to specific connection numbers, and subsequently the IP addresses defined therein.
- Note: A single IB-E module can communicate with 7 (max) other IB-E modules

Receive (from) Node

- This table of IP addresses defines from which nodes the current node will receive messages. Simply drag the target IP address from the Node Tree into the connection sequence. Or, fill in the IP address table manually.

Transmit (to) Node

- This table of IP addresses defines to which nodes the current node will transmit messages. Simply drag the target IP address from the Node Tree into the connection sequence. Or, fill in the IP address table manually.

6. CONFIGURING IB-E

Multicast

- The Multicast option is only available for Transmit Node connection 1. It sends the message to all IP addresses on the network. However, the other IB-E modules must be configured to receive the *multicast* IP address, not the IB-E module's IP address.

Node 100 – Transmitting a multicast message



Node 101 – Receiving a multicast message



The available multicast IP address range is 225.0.0.1 to 225.0.255.254

- Note: Although this may be useful in some situations, it is not intended for use on every IB-E module. Since multicast messages have no defined destination, having too many multicast messages could flood the network and lower its performance.

ACCELERATION/DECELERATION TAB:

- The Acceleration/Deceleration tab allows access to acceleration and deceleration properties. These properties are set independently for each direction of each motor.

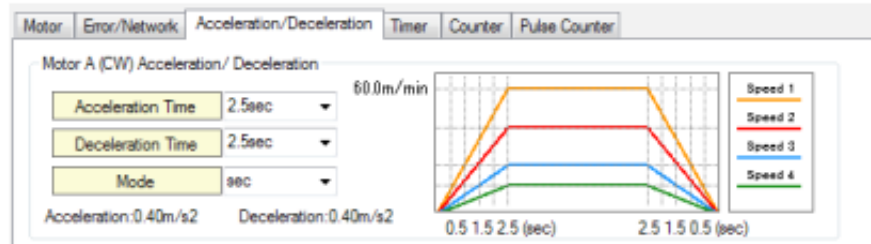

- Note: Acceleration and Deceleration settings are not in effect when switching between set speeds while the motor is running.

Acceleration Time

- The Acceleration Time selection determines time that elapses for a motorized roller to increase its speed from 0 (stopped) to the set speed. The time range is 0 to 2.5s in 0.1s increments.

Deceleration Time

- The Deceleration Time selection determines time that elapses for a motorized roller to decrease its speed from the set speed to 0 (stopped). The time range is 0 to 2.5s in 0.1s increments.

6. CONFIGURING IB-E

Mode

- The Mode selection determines the way in which the acceleration and deceleration functions.
 - Secs – Default setting in which the acceleration and deceleration are based on time (seconds). Each speed setting accelerates/decelerates within the same *time period*.



- m/sec² – This setting sets the acceleration and deceleration on rate, not time. Acceleration/deceleration time values and Speed 1 are used to calculate the rate.

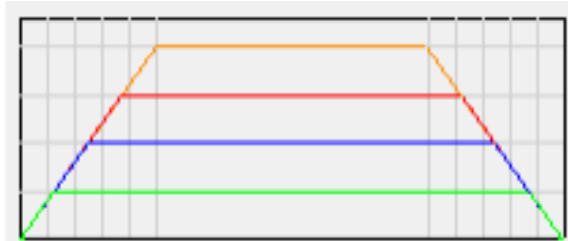

TIMER TAB:

- The Timer Tab allows the user to set the time value for the timers. There are 32 (0-31) 0.01s based timers with a range of 0.00s to 2.55s. There are 32 (32-63) 0.1s based timers with a range of 0.0s to 25.5s.
- When a timer is used in the logic, the comment/name field will be white. If the timer is not used, then this field will be grey. In either case, the comment/name for the timer will be displayed.

Motor		Error/Network		Acceleration/Deceleration		Timer		Counter		Pulse Counter	
				Timer Setting (10msec)				Timer Setting (100msec)			
T0	0.00	▼	sec	10msec	Timer_0	T32	2.5	▼	sec	TimerOFF_32	
T1	0.00	▼	sec	10msec	Timer_1	T33	0.0	▼	sec	100msec Timer_1	
T2	0.00	▼	sec	10msec	Timer_2	T34	0.0	▼	sec	100msec Timer_2	
T3	0.00	▼	sec	10msec	Timer_3	T35	0.0	▼	sec	100msec Timer_3	

COUNTER TAB:

- The Counter Tab allows the user to set the count value for the counters. There are 64 counters (0-63) with a counting range of 0 to 255. When the set count is achieved the counter's output is true.
- When a counter is used in the logic, the comment/name field will be white. If the counter is not used, then this field will be grey. In either case, the comment/name for the counter will be displayed.

Motor		Error/Network		Acceleration/Deceleration		Timer		Counter		Pulse Counter	
Counter											
C0	10	count	CountUP_0	C32	0	count		C33	0	count	
C1	0	count		C34	0	count		C35	0	count	
C2	0	count									
C3	0	count									

6. CONFIGURING IB-E

PULSE COUNTER TAB:

- The Pulse Counter is a special counter that is related to the motor’s revolution. There are 12 pulses per motor revolution. The pulse counter counts these pulses, and when the set count is achieved the pulse counter’s output is true. This tab allows the user to set the count value for the pulse counters. There are 16 counters (0-3 for motor A and 8-15 for motor B) with a counting range of 0 to 65,535.
- When a counter is used in the logic, the comment/name field will be white. If the counter is not used, then this field will be grey. In either case, the comment/name for the counter will be displayed.

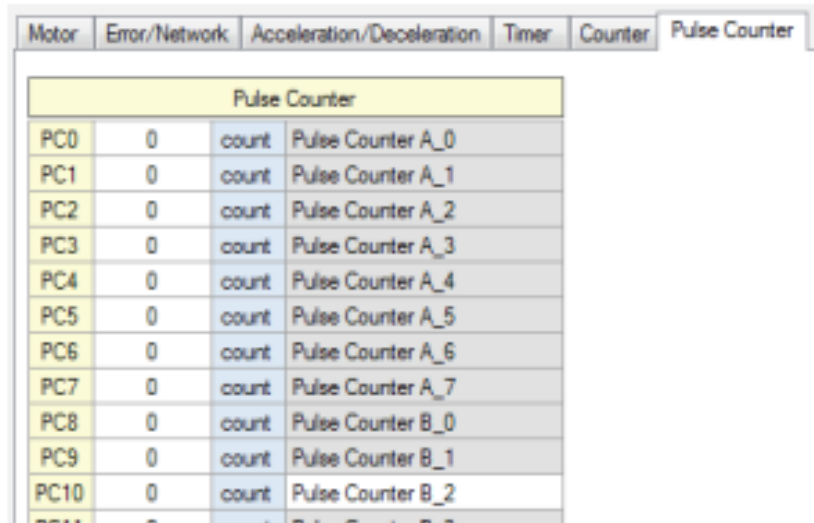

Pulse Counter			
PC0	0	count	Pulse Counter A_0
PC1	0	count	Pulse Counter A_1
PC2	0	count	Pulse Counter A_2
PC3	0	count	Pulse Counter A_3
PC4	0	count	Pulse Counter A_4
PC5	0	count	Pulse Counter A_5
PC6	0	count	Pulse Counter A_6
PC7	0	count	Pulse Counter A_7
PC8	0	count	Pulse Counter B_0
PC9	0	count	Pulse Counter B_1
PC10	0	count	Pulse Counter B_2

MASTER/SLAVE:

- This is the ICE configuration of the IB-E for Master or Slave mode (refer to Chapter 3 – Master Mode and Slave Mode).
- The factory default setting for an IB-E is Slave mode. However since there are no logic and configuration parameters at this time, the IB-E will not operate anyway.
- By default, ICE will set up new nodes in the Node Tree as masters. Once the configuration parameters are downloaded, the mode will be set as a master. To change between the modes

- Select the IP address of the node to change, then right-click on it, and click on “Master/Slave”

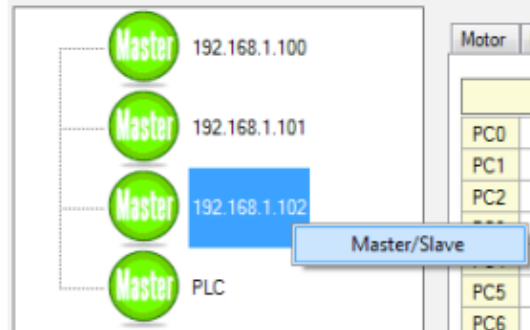

6. CONFIGURING IB-E

- Select “Slave” from the drop-down list under “Mode Select”, and then select the IP address of the IB-E to which this module will be a slave, or “PLC” if it is to be directly controlled through EtherNet/IP with implicit messaging. If switching back to Master mode, select “Master” from the drop-down list under “Mode Select”, and then click “OK”.

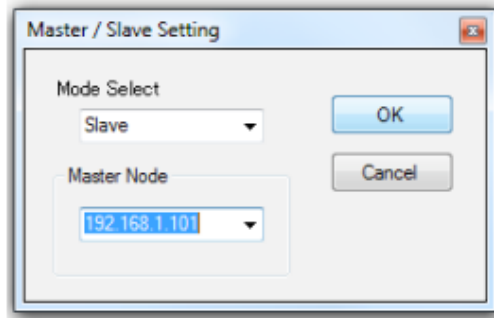

- Expand the IP address of the Master IB-E and the slave will be shown below it.

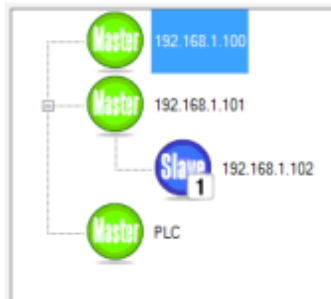

- Each slave IB-E module (IP address) is assigned a number (1-7). This assigned number is directly related to the connection number. Therefore, the slave IB-E modules’ IP addresses must be assigned to the corresponding connection numbers in the Receive and Transmit tables of the Master IB-E.

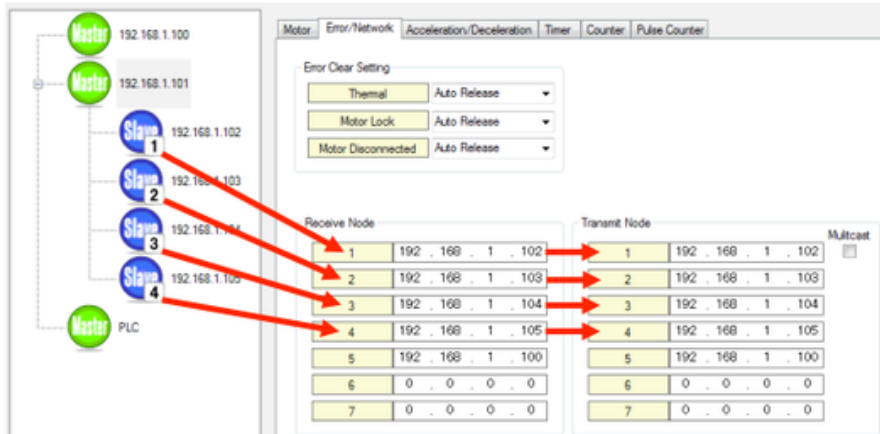

Receive Node	Transmit Node
1 192.168.1.102	1 192.168.1.102
2 192.168.1.103	2 192.168.1.103
3 192.168.1.104	3 192.168.1.104
4 192.168.1.105	4 192.168.1.105
5 192.168.1.100	5 192.168.1.100
6 0.0.0.0	6 0.0.0.0
7 0.0.0.0	7 0.0.0.0

- Note: If all 7 connections are used for slave IB-E modules, then the Master IB-E module will not communicate with any other master IB-E modules.

6. CONFIGURING IB-E

- For each Slave IB-E, go to the Error/Network tab and assign the Master IB-E module's IP address as connection 1. The current node properties shown below are for 102.

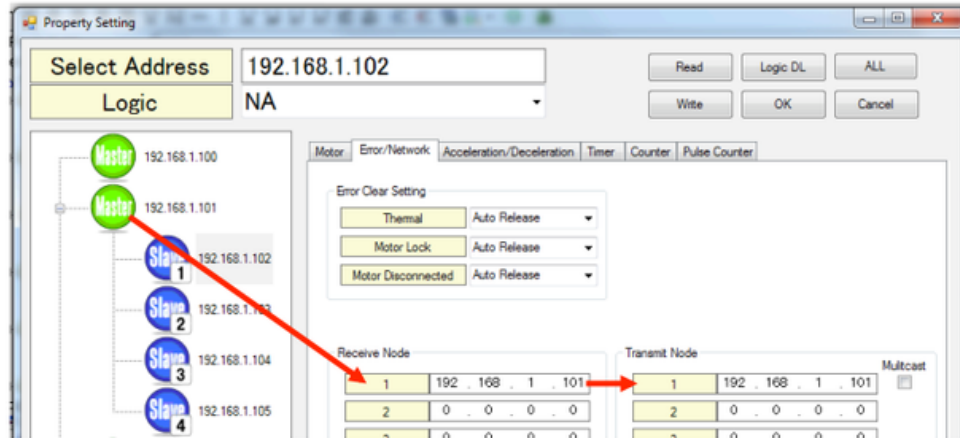

- Note: This table does not have to be populated when the IB-E is set as a slave of the “PLC”

7. LOGIC PROGRAMMING

- The information in this manual is based on the assumption that the user already has a basic understanding of ladder diagram programming and is already familiar with other ladder diagram programming environments.

PROGRAM DISPLAY:

- The Program Display will show the ladder diagram editor for the chosen logic. To make the logic visible in the display, expand the logic from the Project Tree and double-click on “Program”.

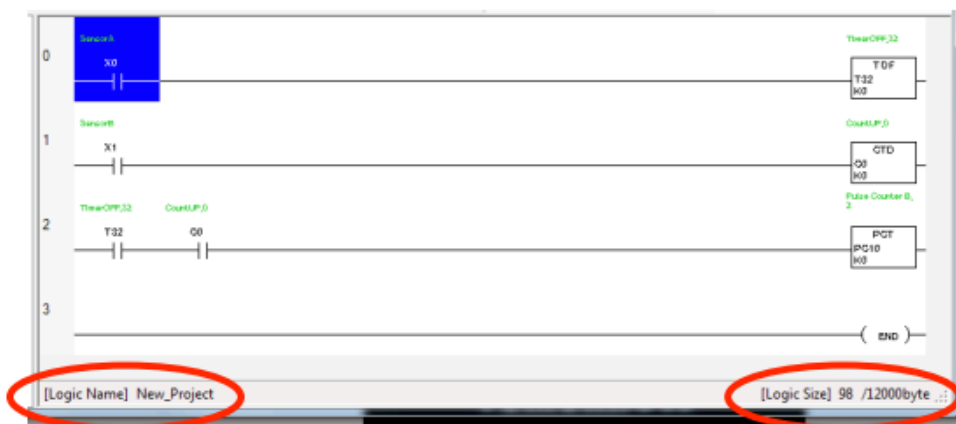
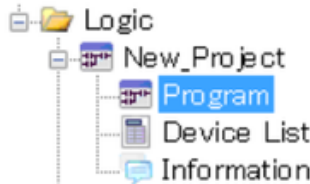

- The name of the current logic shown in the Program Display and its file size is located at the very bottom of the window. The file size is updated each time the logic is compiled.
- Use the Icon Toolbar (Chapter 5) to insert any of the logic elements necessary for the program. Please keep in mind that output related elements could only be inserted or available when they are placed to the far right (end) of the rung.
- Another method to place (or modify) logic elements is to double-click any position in the ladder diagram, as long as it is not the “End” rung. This will open the Command Input window.
- Note: Each rung can have a maximum of 8 lines. Each line can fit a maximum of 10 logic elements, including the output element.

COMMAND INPUT:

- The Command Input window is the main tool for configuring the logic elements in the ladder diagram editor.

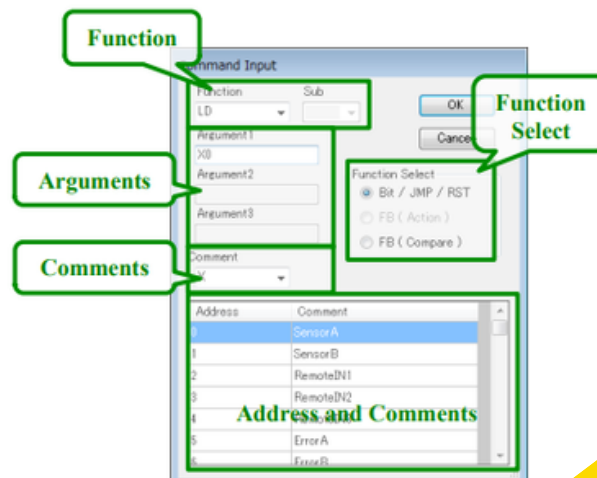

7. LOGIC PROGRAMMING

FUNCTION SELECT:

- The Function Select area switches the logic element between three different operations. These operations are described in detail, later in this chapter.
 - Boolean Functions
 - Action Functions
 - Compare Functions

FUNCTION:

- The Function area is the selection of the specific element within the operation selected by “Function Select”. These operations are described in detail, later in this chapter.

ARGUMENTS:

- The Arguments area allows the user to define parameters for the functions selected. These may be input and output addresses, user-defined constants, data registers, etc.

COMMENT:

- The Comment area is a drop-down list for the different ranges of logic elements. When a range of logic elements is selected, the window below displays logic element addresses. These logic elements are the same as the device list.
 - X – Predefined Boolean input elements (sensors, auxiliary inputs, etc.)
 - Y – Predefined Boolean output elements (motor run, direction change, etc.)
 - M – User-defined Boolean internal elements
 - D – Data registers, 1Byte each, stored in non-volatile memory
 - T – Timers
 - C – Counters
 - PC – Pulse counters
 - S – Special purpose elements
 - SD – Self data register, only used for Node ID
- When an element’s comment displays a number in parenthesis, the number in the parenthesis references the (communication) connection number (refer to Chapter 6 – Receive and Transmit Nodes).

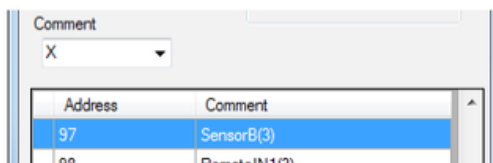

- Input Element: X97
Comment: SensorB(3)
IB-E (IP Address) assigned to Receive Node 3

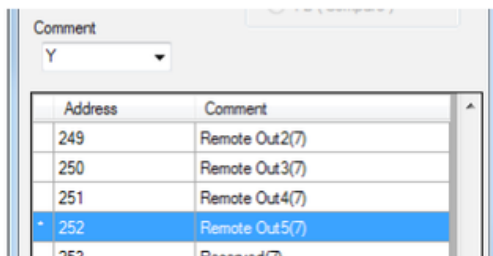

- Output Element: Y252
Comment: Remote Out5(7)
IB-E (IP Address) assigned to Transmit Node 7

7. LOGIC PROGRAMMING

ADDRESS AND COMMENTS:

- The Address and Comments area is populated with a list of addresses that correspond to a range of logic elements selected by the Comment drop-down list. This window displays an element address as well as any pre-defined names, or comments, associated with that address. If no name, or comment, is present, the user could fill in this field with a meaningful description.
- If an output address has been used in the program already, it will be preceded by “**”.
- Note: Although all predefined names can be changed, it is strongly recommended that Input (X) and Output (Y) elements remain unchanged. This makes troubleshooting much easier, since these elements are linked directly to physical connections on, or specific functions within, the IB-E.

BOOLEAN FUNCTIONS:

- These functions only have two states True (On, Energized, 1, etc.) or False (Off, De-energized, 0, etc.)

INPUTS:

- These logic elements must be placed before (left of) the outputs.

LD and LDI

- Type an element address using the Argument field, or use the Comment drop-down list and double-click on the address line.

LD – Normally Open contact



LDI – Normally Closed contact



- Specific bits of data registers could also be assigned using the following format “Dx.y”, where “x” is the data register address and “y” is the bit position (0- 7) within that register.
- For example: D6.0 is the first bit (LSB) for data register 6.
- SD elements cannot be used.

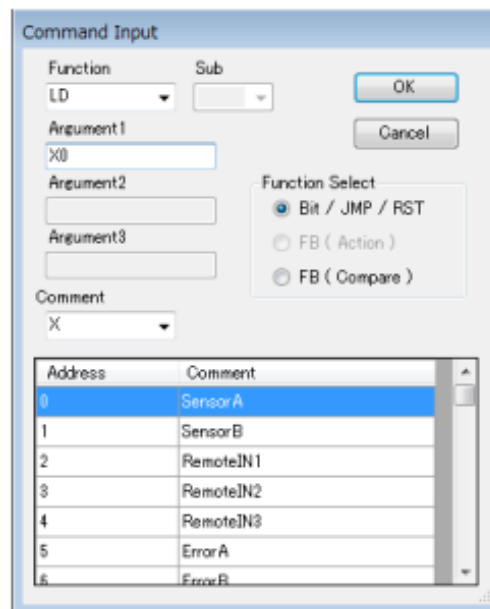

7. LOGIC PROGRAMMING

LDP and LDF

- Type an element address using the Argument field, or use the Comment drop-down list and double-click on the address line.

LDP – Rising-Edge pulse, OFF-to-ON



- When the state of the logic element changes from OFF-to-ON, LDP will be ON for one scan.

LDF – Falling-Edge pulse, ON-to-OFF



- When the state of the logic element changes from ON-to-OFF, LDF will be ON for one scan.
- Data registers cannot be used.
- Y or M elements that have been assigned, as SETs or RSTs, cannot be used. A build error will result.

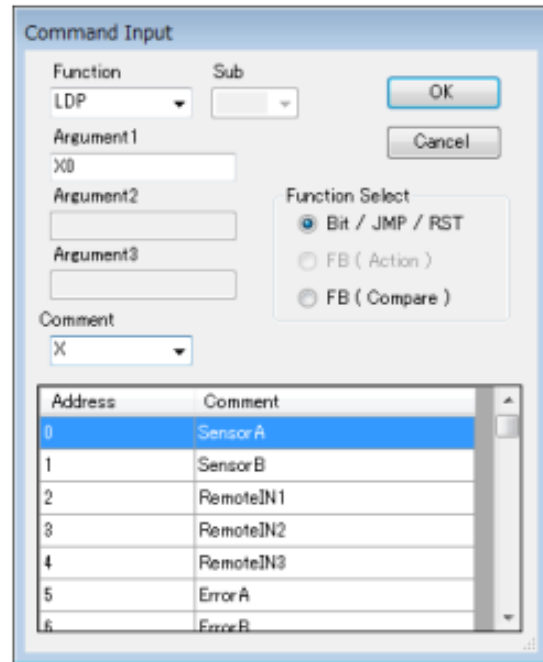

Address	Comment
0	Sensor A
1	Sensor B
2	RemoteIN1
3	RemoteIN2
4	RemoteIN3
5	Error A
6	Error B

OUTPUTS:

- These logic elements must be placed at the end (most right) of the rung

OUT

- Type an element address using the Argument field, or use the Comment drop-down list and double-click on the address line.

OUT – Normally Open output



- Specific bits of data registers could also be assigned using the following format "Dx.y", where "x" is the data register address and "y" is the bit position (0-7) within that register.
- For example: D6.0 is the first bit (LSB) for data register 6.
- Note: D95 to D799 are not available for use.
- Only Y, M, and D elements can be used.
- Each OUT must be unique and never duplicated.

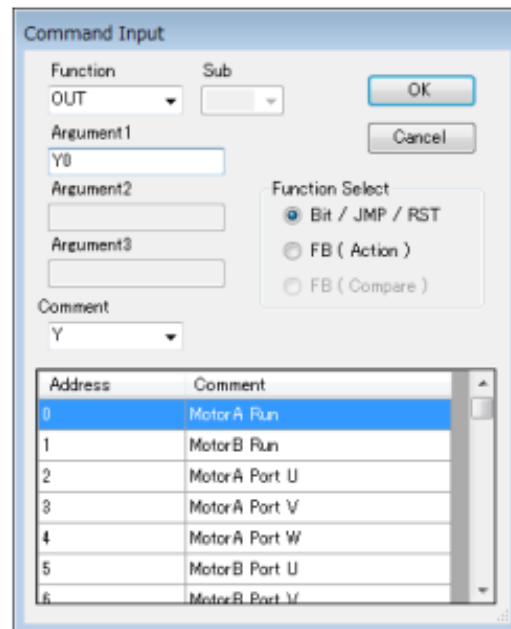

Address	Comment
0	Motor A Run
1	Motor B Run
2	Motor A Part U
3	Motor A Part V
4	Motor A Part W
5	Motor B Part U
6	Motor B Part V

7. LOGIC PROGRAMMING

SET

- Type an element address using the Argument field, or use the Comment drop-down list and double-click on the address line.

SET – Latch, maintains output



- The same specifications for OUT apply to SET.
- Y or M elements that have been assigned as LDPs or LDFs, cannot be used. A build error will result.

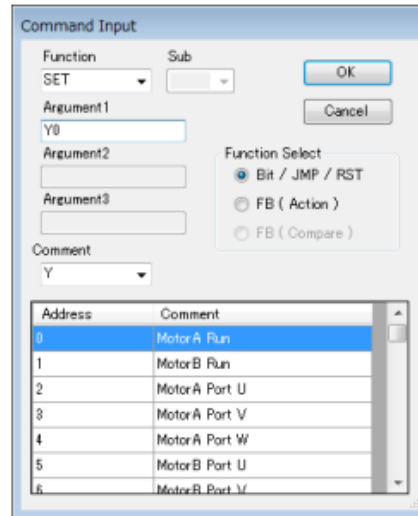

RST

- Type an element address using the Argument field, or use the Comment drop-down list and double-click on the address line.

RST – unlatch, releases output



- The same specifications for OUT apply to RST.
- Y or M elements that have been assigned as LDPs or LDFs, cannot be used. A build error will result.

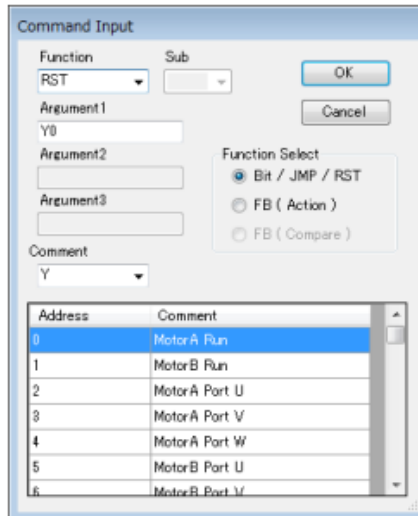

LOGIC OPERATIONS:

INV

- There are no Arguments or Comments available for this function.

INV – Inverts state



- This logic element is placed *between* logic elements on the *same line*.
- If a state is ON before (left of) INV, it will be OFF after (right of) INV.

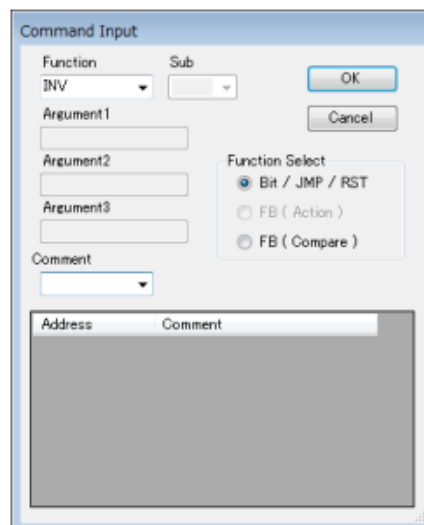

7. LOGIC PROGRAMMING

MEP

- There are no Arguments or Comments available for this function.

MEP – Responds to Rising-Edge state



- This logic element is placed *between* logic elements.
- When the state changes from OFF-to-ON before (left of) MEP, it will be ON after (right of) MEP for one scan.
- Up to 255 MEP elements can be used per logic.

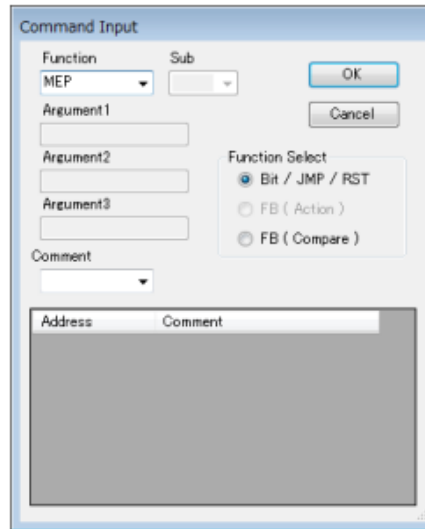

LBL and JMP

- Type an element address using the Argument field.

JMP – Jump from, origin, output (most right)

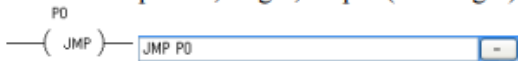

LBL – Jump to, destination, input (most left)



- “Px” is the Argument defining the “jump to” point, where “x” defines the point. The usable range is P0 to P255.
- Any rungs after JMP are ignored, until the rung with LBL in first position. This includes any rungs that follow during the next scan (from beginning).
- JMP and LBL must be used together.

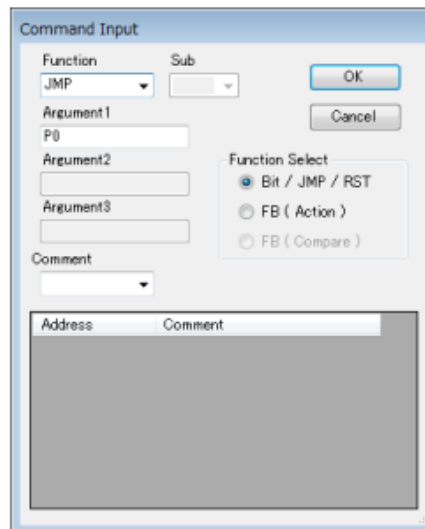

7. LOGIC PROGRAMMING

ACTION FUNCTIONS:

TIMERS:

- T0 to T31 are 0.01s based timers
- T32 to T63 are 0.1s based timers
- For all timers:
 - Argument1 assigns the timer address
 - Type a “T” element address or use the Comment drop-down list and double-click on the timer address line.
 - Argument2 defines the time
 - “Kx” is the value of the timer, where “x” is the time value. The time base of the timer is the multiplier to calculate seconds.
 - For example, T0 is a 0.01s base timer, if Argument2 is K100
 - 100 x 0.01s = 1.00s
 - The time is set for 1 second
 - K65535 is the maximum value
 - “KO” is the only argument setting that allows the timer to be set/adjusted in the Properties Setting window (refer to Chapter 6 – Timer Tab)
 - This allows the user to change timer settings without having to change the logic
 - K255 is the maximum value when using the Property Setting window

TON - Timer ON Delay



- The output of the timer turns ON when the input to the timer has remained ON for the specified value.
- This timer resets whenever the input to the timer is OFF.

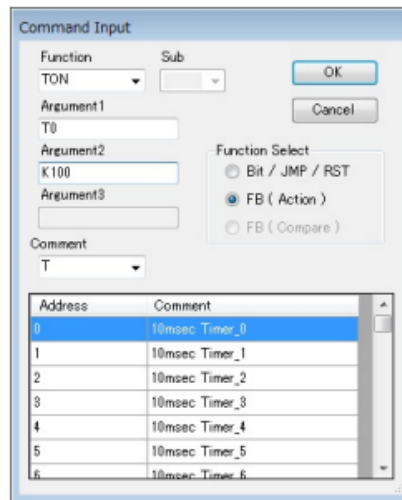

- TON timing chart

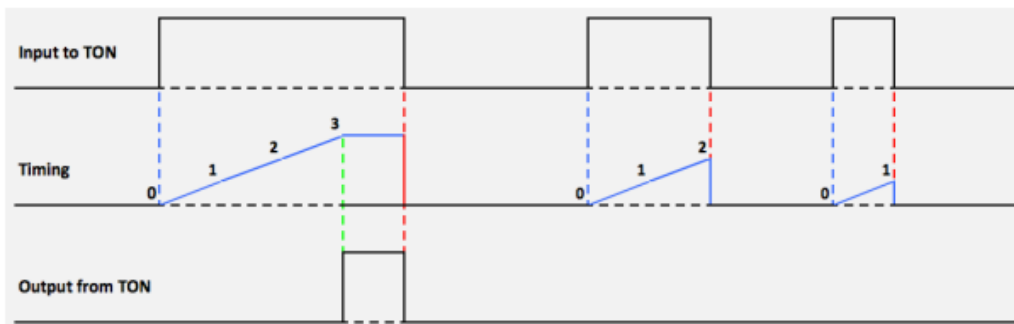

7. LOGIC PROGRAMMING

TOF - Timer OFF Delay



- The output of the timer turns ON when the input to the timer has turned ON. Then, the output of the timer remains ON until the input to the timer turns OFF and remains OFF for the specified value.
- This timer resets whenever the input to the timer turns ON.

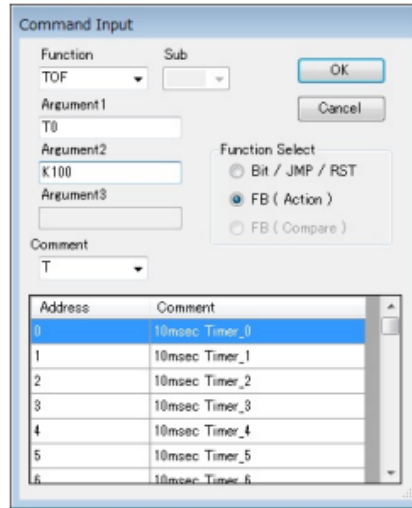

- TOF timing chart

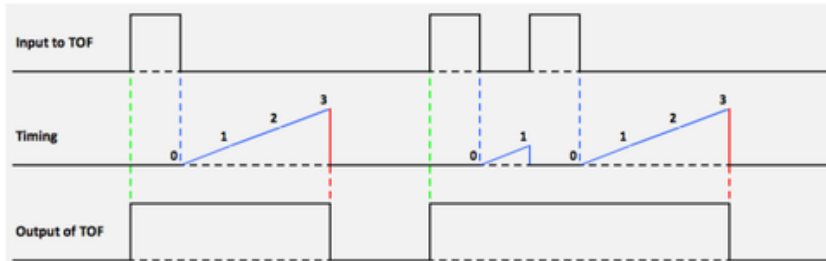

TP - Timer Pulse



- The output of the timer turns ON when the input to the timer has turned ON. Then, the output of the timer remains ON for the specified value.
- This timer resets when both the input and the output of the timer are OFF.

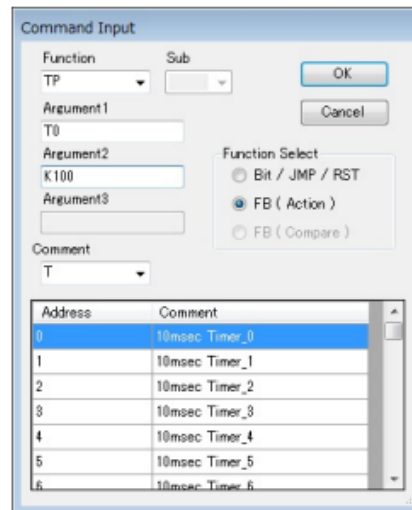

- TP timing chart

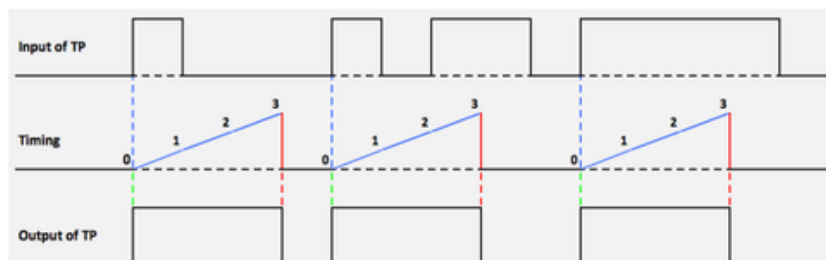

COUNTERS:

- For all counters:
 - Argument1 assigns the counter address
 - Type a “C” element address or use the Comment drop-down list and double-click on the counter address line.
 - Argument2 defines the count
 - “Kx” is the value of the counter, where “x” is the count value
 - “K0” is the only argument setting that allows the counter to be set/adjusted in the Properties Setting window (refer to Chapter 6 – Counter Tab)
 - This allows the user to change counter settings without having to change the logic
 - K255 is the maximum value

CTU - Counter Up



- Each time the counter’s input turns ON, the count increments (+1). The initial count is 0.
- The output of the counter turns ON when the count matches the specified value.
- This counter is reset using the RST output element.

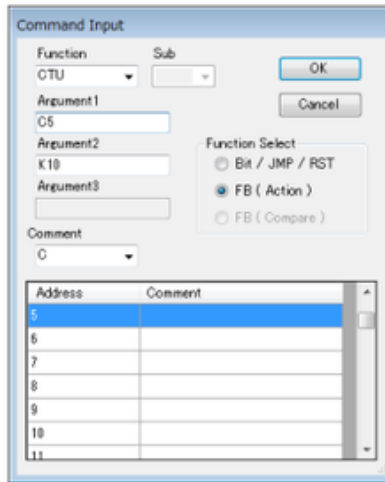

- CTU timing chart

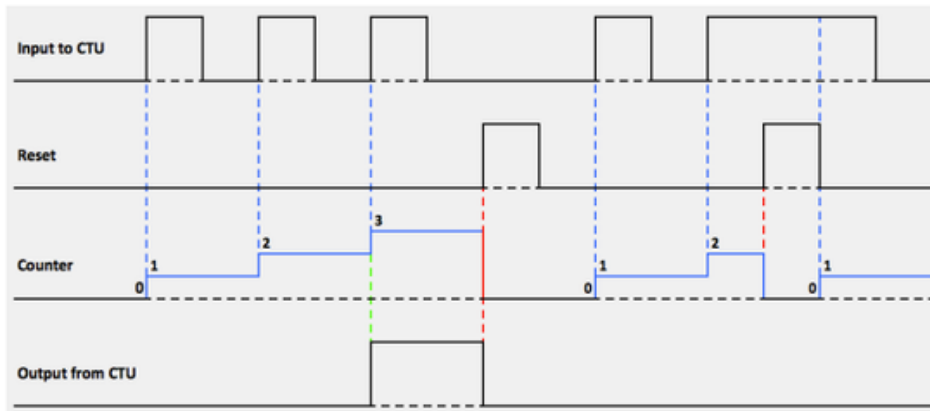

7. LOGIC PROGRAMMING

CTD - Counter Down



- Each time the counter's input turns ON, the count decrements (-1). The initial count is the specified value.
- The output of the counter turns ON when the count matches 0.
- This counter is reset using the RST output element.

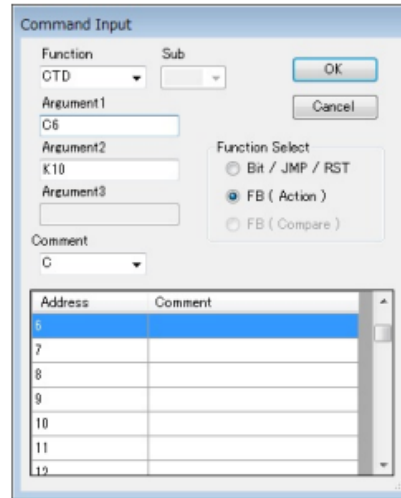

■ CTD timing chart

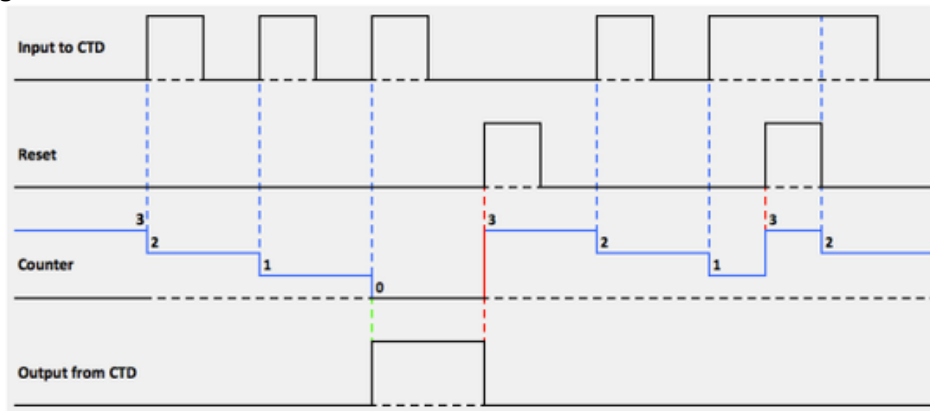

PULSE COUNTERS:

- The Pulse Counters are specialized functions that count motor pulses, signals from the motor's Hall-effect sensors. One revolution of the motor (not tube) is equivalent to 12 pulses. When the input to the Pulse Counter is ON, the motor pulses are counted.
- For all Pulse Counters:
 - Argument1 assigns the pulse counter address
 - Type a "PC" element address or use the Comment drop-down list and double-click on the pulse counter address line.
 - Argument2 defines the number of pulses
 - "Kx" is the value of the counter, where "x" is the count value.
 - "K0" is the only argument setting that allows the pulse counter to be set/adjusted in the Properties Setting window (refer to Chapter 6 – Pulse Counter Tab)
 - This allows the user to change pulse counter settings without having to change the logic

7. LOGIC PROGRAMMING

PCT – Pulse Counter



- The output of the pulse counter turns ON, when the count matches the specified value.
- Motor A uses Pulse Counters 0-3
- Motor B uses Pulse Counters 8-15.
- This counter is reset using the RST output element.

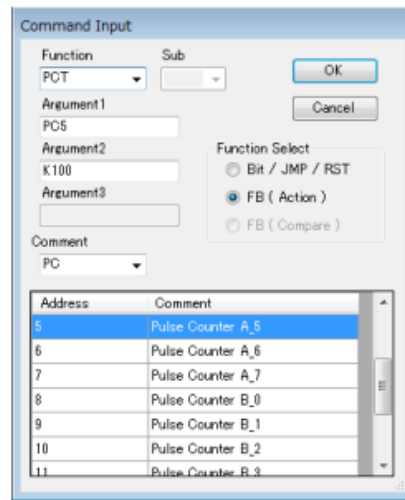

DATA HANDLING:

- The IB-E has data handling capabilities through its data registers, “D” registers listed under Device Type. Each data register is 1 Byte (8 bits) in length.

Available Data Register Ranges	Access	Description
D0 → D15	Read/Write	Data transmitted to other IB-E modules and/or PLC*
D16 → D94	Read/Write	Internal use only
D95 → D110	Read Only	Received data from Connection 1
D190 → D205	Read Only	Received data from Connection 2
D285 → D300	Read Only	Received data from Connection 3
D380 → D395	Read Only	Received data from Connection 4
D475 → D490	Read Only	Received data from Connection 5
D570 → D585	Read Only	Received data from Connection 6
D665 → D680	Read Only	Received data from Connection 7
D760 → D775	Read Only	Received data from PLC
All Others	No Access	Reserved

* Only 16 Bytes of data are transmitted by an IB-E module

- It is important to understand the relationships between data internal to the current IB-E module and data from other IB-E modules.
- The tables below show where the current IB-E stores the data from the other IB-E module connections, which are defined by the Receive Node IP address table

IP Address (Source)	D0 (MSB)	D1	D2	D3	D4	D5	D6	D7	D8	D9	D10	D11	D12	D13	D14	D15 (LSB)
↓	↓	↓	↓	↓	↓	↓	↓	↓	↓	↓	↓	↓	↓	↓	↓	↓
Connection 1	D95 (MSB)	D96	D97	D98	D99	D100	D101	D102	D103	D104	D105	D106	D107	D108	D109	D110 (LSB)

IP Address (Source)	D0 (MSB)	D1	D2	D3	D4	D5	D6	D7	D8	D9	D10	D11	D12	D13	D14	D15 (LSB)
↓	↓	↓	↓	↓	↓	↓	↓	↓	↓	↓	↓	↓	↓	↓	↓	↓
Connection 2	D190 (MSB)	D191	D192	D193	D194	D195	D196	D197	D198	D199	D200	D201	D202	D203	D204	D205 (LSB)

IP Address (Source)	D0 (MSB)	D1	D2	D3	D4	D5	D6	D7	D8	D9	D10	D11	D12	D13	D14	D15 (LSB)
↓	↓	↓	↓	↓	↓	↓	↓	↓	↓	↓	↓	↓	↓	↓	↓	↓
Connection 3	D285 (MSB)	D286	D287	D288	D289	D290	D291	D292	D293	D294	D295	D296	D297	D298	D299	D300 (LSB)

IP Address (Source)	D0 (MSB)	D1	D2	D3	D4	D5	D6	D7	D8	D9	D10	D11	D12	D13	D14	D15 (LSB)
↓	↓	↓	↓	↓	↓	↓	↓	↓	↓	↓	↓	↓	↓	↓	↓	↓
Connection 4	D380 (MSB)	D381	D382	D383	D384	D385	D386	D387	D388	D389	D390	D391	D392	D393	D394	D395 (LSB)

IP Address (Source)	D0 (MSB)	D1	D2	D3	D4	D5	D6	D7	D8	D9	D10	D11	D12	D13	D14	D15 (LSB)
↓	↓	↓	↓	↓	↓	↓	↓	↓	↓	↓	↓	↓	↓	↓	↓	↓
Connection 5	D475 (MSB)	D476	D477	D478	D479	D480	D481	D482	D483	D484	D485	D486	D487	D488	D489	D490 (LSB)

IP Address (Source)	D0 (MSB)	D1	D2	D3	D4	D5	D6	D7	D8	D9	D10	D11	D12	D13	D14	D15 (LSB)
↓	↓	↓	↓	↓	↓	↓	↓	↓	↓	↓	↓	↓	↓	↓	↓	↓
Connection 6	D570 (MSB)	D571	D572	D573	D574	D575	D576	D577	D578	D579	D589	D581	D582	D583	D584	D585 (LSB)

IP Address (Source)	D0 (MSB)	D1	D2	D3	D4	D5	D6	D7	D8	D9	D10	D11	D12	D13	D14	D15 (LSB)
↓	↓	↓	↓	↓	↓	↓	↓	↓	↓	↓	↓	↓	↓	↓	↓	↓
Connection 7	D665 (MSB)	D666	D667	D668	D669	D670	D671	D672	D673	D674	D675	D676	D677	D678	D679	D680 (LSB)

IP Address (Source)	D0 (MSB)	D1	D2	D3	D4	D5	D6	D7	D8	D9	D10	D11	D12	D13	D14	D15 (LSB)
↓	↓	↓	↓	↓	↓	↓	↓	↓	↓	↓	↓	↓	↓	↓	↓	↓
PLC Connection	D760 (MSB)	D761	D762	D763	D764	D765	D766	D767	D768	D769	D770	D771	D772	D773	D774	D775 (LSB)

Receive Node	
1	192 . 168 . 1 . 203
2	192 . 168 . 1 . 202
3	192 . 168 . 1 . 206
4	0 . 0 . 0 . 0
5	0 . 0 . 0 . 0
6	0 . 0 . 0 . 0
7	0 . 0 . 0 . 0

- For example in the settings above, the 16 Bytes of data from:
 - IP address 192.168.1.203 are stored in D95 to D110 (Connection 1)
 - IP address 192.168.1.202 are stored in D180 to D205 (Connection 2)
 - IP address 192.168.1.206 are stored in D285 to D300 (Connection 3)
- Connections 4 through 7 have no IP address assigned.

7. LOGIC PROGRAMMING

MOVE FUNCTIONS:

- These operations take data from one location and put it into another. The data can reside in a single data register (1 Byte) or in multiple registers. However, this is more of a *copy* function, since the source data is not deleted.

MOV - Move

- Argument1 – Data source
- Argument2 – Data destination (D0 to D94)



- Note: A constant (K0 to K255) can be used as source data when moving to a single data register (1 Byte). Otherwise, data registers must be moved to other data registers.

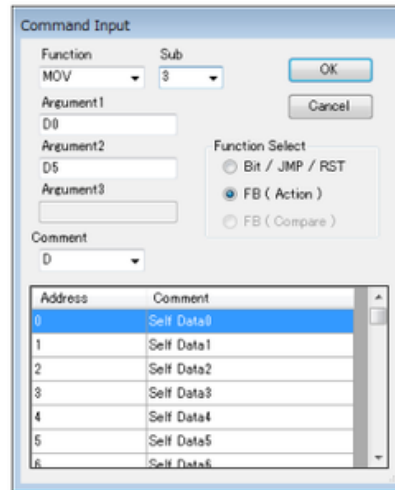

Sub - length, number of data registers in Bytes (up to 4)

- 1 – 1 data register each
 - Ex. D0 moved to D5

Argument1	→	Argument2
D0		D5

Move

D0	→	D5
10		0

Complete

D0		D5
10		10

- 2 – 2 data registers each
 - Ex. D0 and D1 moved to D5 and D6, respectively

Argument1	→	Argument2
D0 D1		D5 D6

Move

D0 D1	→	D5 D6
10 11		0 0

Complete

D0 D1		D5 D6
10 11		10 11

7. LOGIC PROGRAMMING

- 3 – 3 data registers each
 - Ex. D0 to D2 moved to D5 to D7, respectively

Argument1			→	Argument2		
D0	D1	D2		D5	D6	D7

Move

D0	D1	D2	→	D5	D6	D7
10	11	12		0	0	0

Complete

D0	D1	D2		D5	D6	D7
10	11	12		10	11	12

- 4 – 4 data register each
 - Ex. D0 to D3 moved to D5 to D8, respectively

Argument1				→	Argument2			
D0	D1	D2	D3		D5	D6	D7	D8

Move

D0	D1	D2	D3	→	D5	D6	D7	D8
10	11	12	13		0	0	0	0

Complete

D0	D1	D2	D3		D5	D6	D7	D8
10	11	12	13		10	11	12	13

FMOV - Fill Move

- FMOV takes the data of a single data register and copies that data into a range data registers.
- Argument1 – Data source (1 Byte)
- Argument2 – Data destination (start point)
- Argument3 – Total number of registers (Bytes) to fill



- Note: A constant (K0 to K255) can also be used as source data. A constant (K1 to K95) must be used for Argument3. D95 and above cannot be filled.

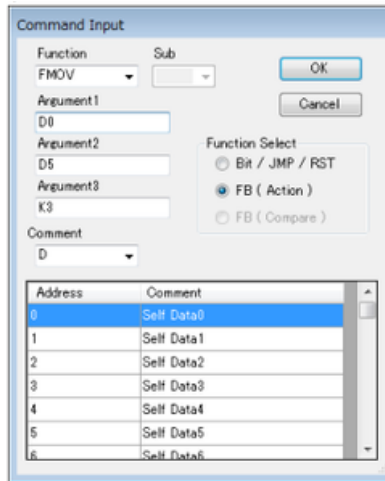

- Ex. D0 moved to D5 to D7 (3 Bytes)

Argument1	→	Argument2		
D0		D5	D6	D7

Move

D0	→	D5	D6	D7
10		0	0	0

Complete

D0		D5	D6	D7
10		10	10	10

7. LOGIC PROGRAMMING

ZRST – Zero Reset

- This function sets defined data registers or internal contacts/coils to “0” or OFF.
- Argument1 – Starting point
- Argument2 – Range of registers or contacts/coils including the starting point



- Note: For “D” registers, K = 1 to 95 (D0 to D94). For “M” contacts/coils, K = 1 to 255 (M0 to M254)

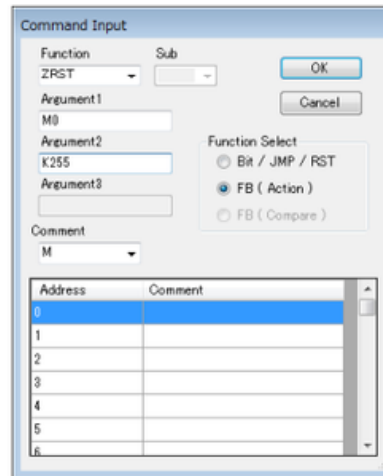

COMPARE FUNCTIONS:

- These operations compare a data register or data registers to either a constant or other data registers. They are considered inputs (left of output element) to the logic. The following compare functions are available:
 - EQ (=) – Argument1 is equal to Argument2
 - GE (>=) – Argument1 is greater than or equal to Argument2
 - GT (>) – Argument1 is greater than Argument2
 - LE (<=) – Argument1 is less than or equal to Argument2
 - LT (<) – Argument1 is less than Argument2
 - NE (!=) – Argument1 is not equal to Argument2

Compare functions



- D0 is equal to D95
- Note: A constant (“K”) can be used when comparing to, or against, a *single* data register (1 Byte). Otherwise, data registers must be compared to, or against, other data registers.
- SD0 – Contains the Node ID (last octet) and is a special data register that can be used in compare functions.

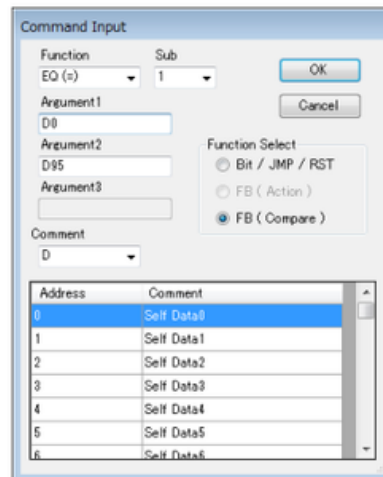

Sub – defines the number of data registers or Bytes to compare. The register shown is always the most significant Byte (starting register).

- 1 – 1 data register each
 - Ex. D0 compared to D95

Argument1	<	Argument2
D0		D95

7. LOGIC PROGRAMMING

- 2 – 2 data registers each
 - Ex. D0 and D1 compared to D95 and D96

Argument1		<	Argument2	
D0	D1		D95	D96

- 3 – 3 data registers each
 - Ex. D0 to D2 compared to D95 to D97

Argument1			<	Argument2		
D0	D1	D2		D95	D96	D97

- 4 – 4 data registers each
 - Ex. D0 to D3 compared to D95 to D98

Argument1				<	Argument2			
D0	D1	D2	D3		D95	D96	D97	D98

MOTOR POSITIONING:

- Motor positioning is accomplished using the motor pulses that are based on motor (not tube) revolution. The motor positioning function(s) runs the motor automatically while it is active. Direction is dependent upon the sign of the constant value (+ or -). The motor positioning functions are considered output elements. As the motor A or B runs, the YO or Y1 elements will be active, respectively.
 - Sub – The motor (A or B) utilizing the positioning function.
 - Argument1 – The target logic element that turns ON when the function is true. Only “M” elements are usable.
 - Argument2 – The defined number of pulses/position that the motor revolves. Only constants “K” are usable. The actual (physical) position of the motor will not match the pulses/position exactly. There will always be some overrun due to inertia.
- Note: When using multiple motor positioning functions for the same motor, the first function in the ladder sequence will have priority.

MRA – Motor Run Absolute

- Motor Run Absolute runs the motor to a specific (pulse) position defined by Argument2. The zero position (K0) is the position of the roller when the IB-E powers ON.



- Minimum K value: -32,768
- Maximum K value: 32,767
- To reset the zero or starting point, use RZP

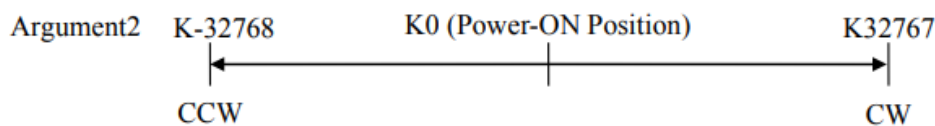
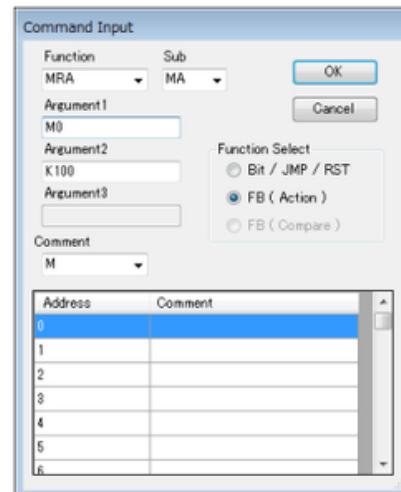

7. LOGIC PROGRAMMING

RZP – Reset Zero Point

- When active, this function sets the current position of the motor as the zero point for the MRA function



- In case entering in Advance Mode, enter 1 for MA and 2 for MB

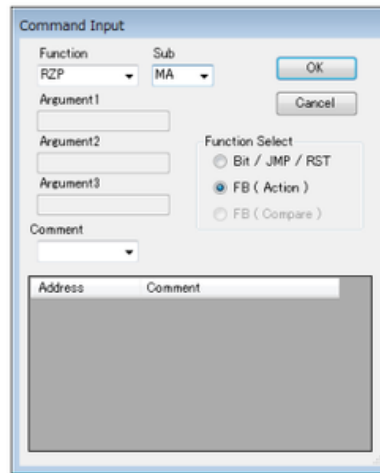

Command Input dialog box for RZP. Function: RZP, Sub: MA. Function Select: FB (Action).

MRI – Motor Run Increment

- This function is similar to MRA, except that whenever the command is active, it always starts at zero. The pulses/position are always counted from the current position.

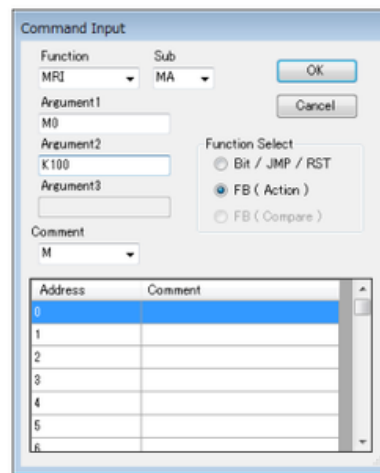
Command Input dialog box for MRI. Function: MRI, Sub: MA. Argument2: K100. Function Select: FB (Action).

Address	Comment
0	
1	
2	
3	
4	
5	
6	

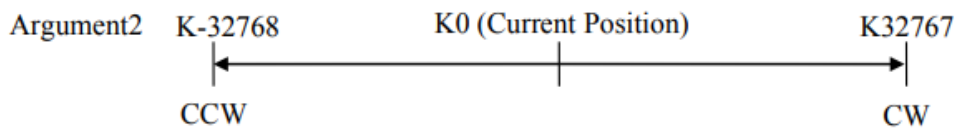

7. LOGIC PROGRAMMING

MRIC – Motor Run Increment Correction

- This function is similar to the MRI function, except it corrects for the overrun by adding (or subtracting, depending on direction) the previous “extra” pulses the next time it is active.

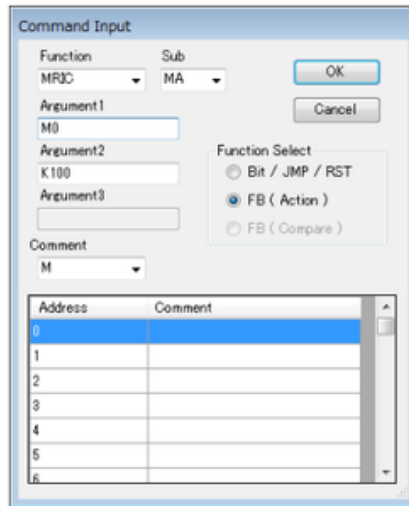

- Ex. Motor A runs for +100 (CW) pulses then stops. Due to inertia, the motor’s actual pulse position is 105. When activated again, the same MRIC function will run motor A for +95 pulses.
- Ex. Motor A runs for -100 (CCW) pulses then stops. Due to inertia, the motor’s actual pulse position is -108. When another MRIC function is activated for +100 (CW) pulses, motor A will run for +108

BUILD (COMPILE):

- Before any logic can be used, or any changes take effect, the logic must be compiled using the “build” function. This can be done while the logic to be built/compiled is open in the Program Display.
- Build is available on the main menu, as well as an icon in the icon toolbar.
- If a build is unsuccessful, an error will result and be displayed in a window. By double-clicking on the error, the error selected will then be displayed in the Program Display and highlighted in red.

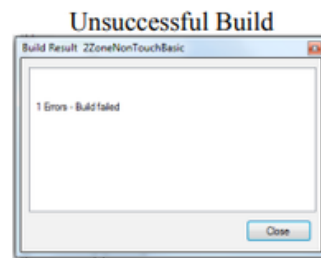
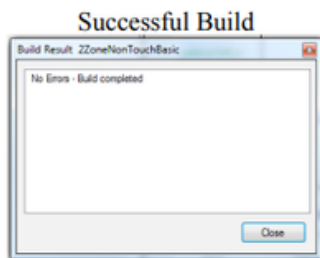

Error in Program Display

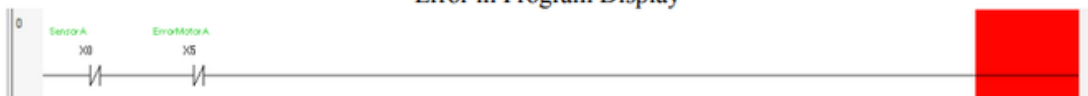

8. TROUBLESHOOTING

MOTOR DRIVER ERROR CONDITIONS:

Error Type	Priority	Suspected Cause	Suggested Solution	Reset Method	IB-E Logic	Motor	
Low Voltage	1	Supply voltage < 20V DC	Maintain supply voltage \geq 20V DC	Automatic	Stop		
Fuse Blown		Fuse is blown	Replace IB-E	-			
Motor Disconnected	2	Motor is not connected	Connect motor	Automatic or Manual	Run	Stop	
Motor Stalled	3	Motor does not run (stalled)	Clear the issue which prevents the motorized roller from turning	Automatic* or Manual			
PCB Thermal	4	High temperature on circuit board	Allow circuit board to cool	Automatic or Manual			
Motor Thermal	5	High temperature in motor	Allow motor to cool	Automatic or Manual			
Back EMF (Overspeeding)	6	Generated voltage from motor \geq 60V DC, at least 0.1 second or \geq 40V DC, at least 2 seconds	Remove the cause of overspeeding, then reset the error from the controller or by cycling 24V DC power	Manual			
Motor Port (discrete output) current limit		\geq 4A, at least 0.1 second	Remove the cause for the high current draw	Manual			
Jam	7	ICE logic element output is active	Remove the cause of error or review ICE logic for output conditions	Based on logic conditions			Based on logic conditions
Sensor Timer	8						
Sensor Alarm	9	Occurs when the (sensor) Alarm signal is active	Check the sensor or wiring of the sensor connection	Automatic			

* "Automatic" reset from a motor stalled error requires the motorized roller to be turned by hand (manually).

Error Reset

- Refer to Chapter 5 – Error Information to reset error statuses using ICE.

PHYSICAL BEHAVIOR:

The motorized roller is not running at the set (linear/surface) speed.

- Check the “Motor” tab under properties for the following:
 - Gear Reduction setting matches the correct motorized roller model
 - Speed setting is for the correct time base
 - Roller Diameter is set correctly for millimeters
 - Roller Speed(s) are set correctly and that the logic is using the correct speed setting output
- Check input power (refer to Chapter 1 – Power Requirements)
- Make sure the motorized roller is mounted properly

The motorized roller is running in the wrong direction.

- Check “Motor” tab under properties for the following:
 - Motor Type setting matches the correct roller model
 - Direction is set for the correct default motor direction
- Check DIP switch 1 and/or 2 (refer to Chapter 1 – Rotary Switches and DIP Switches)
- Check that the logic is using (or not using) the motor direction output

The motorized roller does not run.

- Make sure “Motor Port Setting” in the “Motor” tab under properties is set as “Motor”
- Check that the logic is using the correct motor output
- Check the status LEDs on the IB-E (refer to Chapter 1 – LED Indicators)
- Check DIP switch 3 and/or 4 (refer to Chapter 1 – Rotary Switches and DIP Switches)
- Make sure the motorized roller is mounted properly

There is no response to the sensor input.

- Make sure the sensor is powered
- Make sure the sensor is wired correctly (refer to Chapter 1 – Hardware connections)
- Check the status LEDs on the IB-E (refer to Chapter 1 – LED Indicators)
- Check the logic for the correct sensor input

There is no response to the remote (auxiliary) input.

- Make sure the input (device) and common are wired correctly (refer to Chapter 1 – Hardware connections and Chapter 2 – General Wiring and Precautions)
- Check the status LEDs on the IB-E (refer to Chapter 1 – LED Indicators)
- Check the logic for the correct remote input

The remote (auxiliary) output does not turn on.

- Make sure the output (device) and common are wired correctly (refer to Chapter 1 – Hardware connections and Chapter 2 – General Wiring and Precautions)
- Check the status LEDs on the IB-E (refer to Chapter 1 – LED Indicators)
- Check the logic for the correct remote output

8. TROUBLESHOOTING

The Discrete Output from the motor port does not work.

- Make sure “Motor Port Setting” in the “Motor” tab under properties is set as “Port(Nch)”
- Make sure the output is wired correctly (refer to Chapter 1 – Hardware connections and Chapter 2 – General Wiring and Precautions)
- Check the status LEDs on the IB-E (refer to Chapter 1 – LED Indicators)
- Check the logic for the correct discrete motor port output

SOFTWARE ISSUES:

Read/write (configuration or logic) failure

- Check the IP address settings on the IB-E (refer to Chapter 1 – Rotary Switches and DIP Switches)
- Check the IP address setting in ICE (refer to Chapter 5 – Project Tree)
- Check the PC’s IP address (refer to Chapter 6 – Property Setting)
- Check the PC’s firewall settings (refer to Chapter 4 – Windows Firewall)
- Make sure the IB-E has had enough time to reboot between consecutive writes/downloads.

Monitor not responding to status changes

- Check the IP address settings on the IB-E (refer to Chapter 1 – Rotary Switches and DIP Switches)
- Check the IP address setting in ICE (refer to Chapter 5 – Project Tree)
- Check the PC’s IP address (refer to Chapter 6 – Property Setting)
- Check the PC’s firewall settings (refer to Chapter 4 – Windows Firewall)
- Make sure the IB-E has had enough time to reboot between consecutive writes/downloads.

MODULE RESET:

- The module can be reset to factory defaults. Normally, this is not necessary.

- 1. Power OFF the IB-E, set both rotary switches to “0”, set DIP switches 1 and 2 to the OFF position, and set DIP switches 3 and 4 to the ON position.

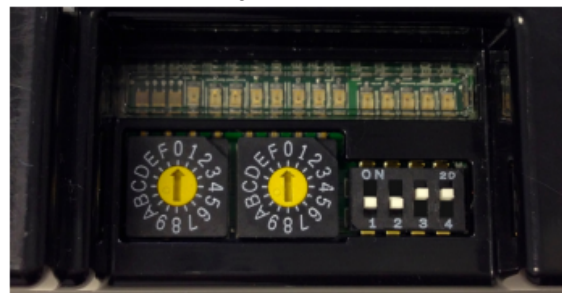

- 2. Power ON the IB-E and wait for the central LED indicators to light up.



- 3. Power OFF the IB-E and set the rotary switches and the DIP switches to the previous (or other operational) settings.

- 4. Power ON the IB-E and use as normal.

9. PLC CONNECTION

OVERVIEW:

- The IB-E is able to connect and be controlled by a controller/processor/PLC through *EtherNet/IP implicit messaging*. In order for the IB-E to be controlled by the PLC, the IB-E must be set as a slave to the PLC (refer to Chapter 6 – Master/Slave). However whether the IB-E is a master or a slave, it can still send status information (motors, sensors, errors, etc.) to the PLC via EtherNet/IP implicit messaging.
- Note: The slave setting is default “out of the box”. It would only be necessary to configure the IB-E as a slave, if it was already configured as a master.

ROCKWELL AUTOMATION PROCESSOR (PLC):

- There are two methods to connect an IB-E to a Rockwell Automation EtherNet/IP processor (ControlLogix, CompactLogix, and SoftLogix) via implicit messaging:

ADD-ON-PROFILE (EASIEST) FOR IB-E03 (COMPATIBLE):

- The Add-On-Profile (AOP) is an installable feature to the Logix 5000 platform (RSLogix 5000/Studio 5000 Logix Designer). The AOP provides a graphical user interface to configure the operational parameters of the IB-E. It is essentially a “Logix” version of the ICE’s property settings window (refer to Chapter 6 – Property Setting). When the AOP is used, all the logic resides within the PLC. And, the AOP provides pre-named tags for input, output, and configuration.
- The AOP is available from Itoh Denki: <https://itohdenki.com/ib-e-downloads>
- Note: It is strongly recommended to review the basic module information (BMI) located via a link under the “Vendor” tab.



- Help information is also available for the specific configuration tabs by clicking on the “Help” button (scroll down).

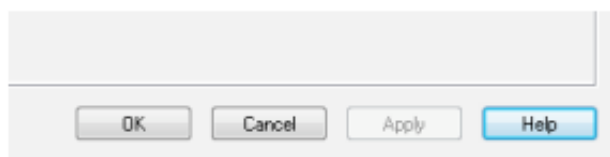

9. PLC CONNECTION

GENERIC ETHERNET MODULE:

- The IB-E can also be added to the PLC as a generic Ethernet module. In this case, the IB-E must be configured via ICE. The pre-named tags for input, output, and configuration are not available. Therefore, these data points must be user-named.

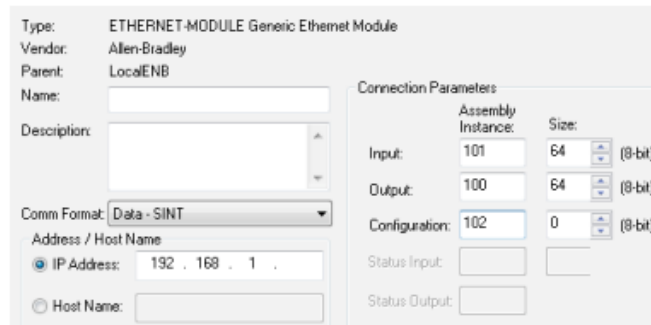

Input Data

Location	Description
I.Data[0] ~ I.Data[3]	Reserved
I.Data[4].0	Sensor A
I.Data[4].1	Sensor B
I.Data[4].2	Sensor Alarm A
I.Data[4].3	Sensor Alarm B
I.Data[4].4	Motor A
I.Data[4].5	Motor B
I.Data[4].6 ~ I.Data[4].7	Reserved
I.Data[5].0	Error Motor A – Back EMF
I.Data[5].1	Error Motor A – Discrete Output Current
I.Data[5].2	Error Motor A – Motor Thermal
I.Data[5].3	Error Motor A – Driver Thermal
I.Data[5].4	Error Motor A – Stalled
I.Data[5].5	Error Motor A – Disconnected/Unplugged
I.Data[5].6	Error Motor A – Jam
I.Data[5].7	Error Motor A – Sensor Timer Jam
I.Data[6].0	Error Motor B – Back EMF
I.Data[6].1	Error Motor B – Discrete Output Current
I.Data[6].2	Error Motor B – Motor Thermal
I.Data[6].3	Error Motor B – Driver Thermal
I.Data[6].4	Error Motor B – Stalled
I.Data[6].5	Error Motor B – Disconnected/Unplugged
I.Data[6].6	Error Motor B – Jam
I.Data[6].7	Error Motor B – Sensor Timer Jam
I.Data[7].0	Remote Input 1
I.Data[7].1	Remote Input 2
I.Data[7].2	Remote Input 3
I.Data[7].3 ~ I.Data[7].7	Reserved
I.Data[8] ~ I.Data[23]	IB-E Data (16 Bytes)
I.Data[24] ~ I.Data[27]	Lifetime for Motor A
I.Data[28] ~ I.Data[31]	Lifetime for Motor B
I.Data[32] ~ I.Data[63]	Reserved

Output Data

Location	Description
O.Data[0].0	Motor A
O.Data[0].1	Motor B
O.Data[0].2	Motor A – Discrete Output U
O.Data[0].3	Motor A – Discrete Output V
O.Data[0].4	Motor A – Discrete Output W
O.Data[0].5	Motor B – Discrete Output U
O.Data[0].6	Motor B – Discrete Output V
O.Data[0].7	Motor B – Discrete Output W
O.Data[1].0	Motor A – Speed1
O.Data[1].1	Motor A – Speed2
O.Data[1].2	Motor A – Speed3
O.Data[1].3	Motor A – Speed4
O.Data[1].4	Motor B – Speed1
O.Data[1].5	Motor B – Speed2
O.Data[1].6	Motor B – Speed3
O.Data[1].7	Motor B – Speed4
O.Data[2].0	Motor A – Disable Acceleration
O.Data[2].1	Motor B – Disable Acceleration
O.Data[2].2	Motor A – Disable Deceleration
O.Data[2].3	Motor B – Disable Deceleration
O.Data[2].4	Motor A – Direction Change
O.Data[2].5	Motor B – Direction Change
O.Data[2].6	Motor A – Error Reset
O.Data[2].7	Motor B – Error Reset
O.Data[3].0	Remote Output 1
O.Data[3].1	Remote Output 2
O.Data[3].2	Remote Output 3
O.Data[3].3	Remote Output 4
O.Data[3].4	Remote Output 5
O.Data[3].5 ~ O.Data[3].7	Reserved
O.Data[4] ~ O.Data[19]	Data (16 Bytes)
O.Data[20] ~ O.Data[63]	Reserved

OTHER ETHERNET/IP PROCESSORS (PLC):

- As long as the PLC communicates to its devices using EtherNet/IP implicit messaging, then these PLCs would be applicable with the IB-E modules.
- Basic connection parameters are the same as the generic Ethernet module shown previously. An electronic data sheet (EDS) may facilitate connection settings between the PLC and the IB-E.
- The EDS is available from Itoh Denki: <https://itohdenki.com/ib-e-downloads>
- Input and output data is the same as the generic Ethernet module shown previously.